

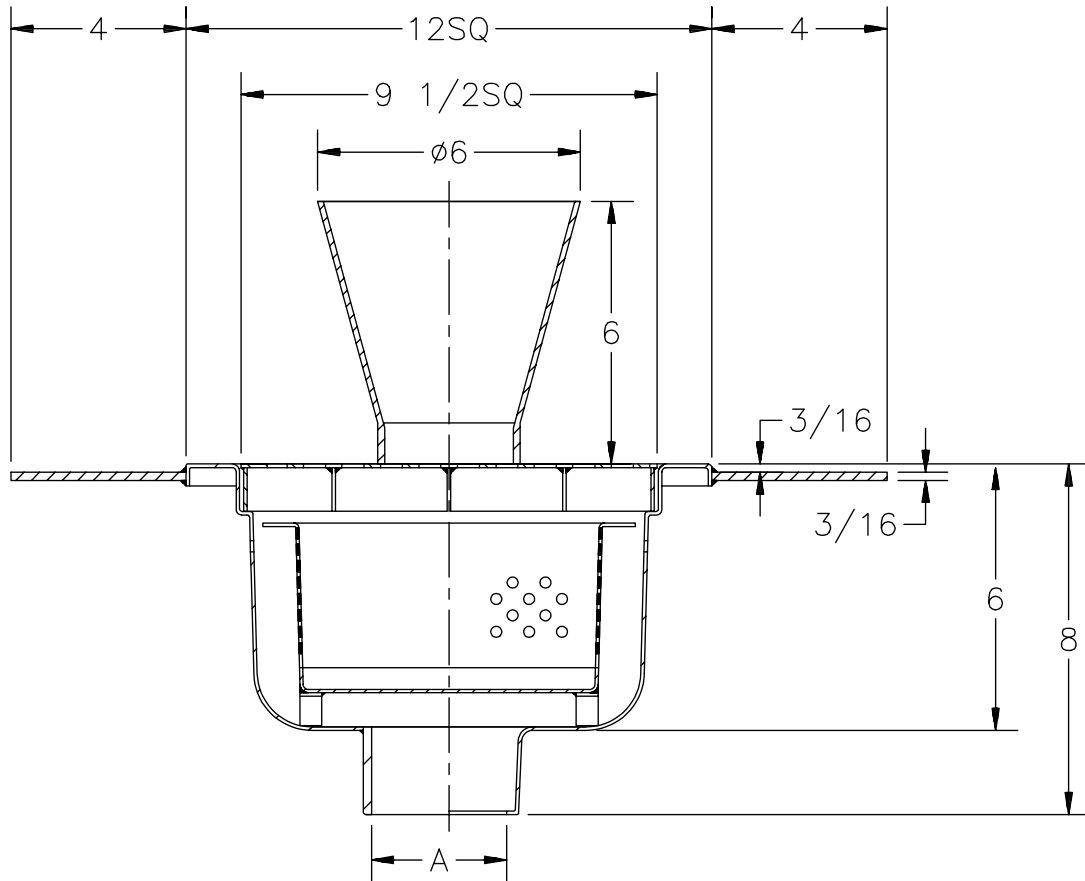

Z-1750-87
12" x 12" SANI-FLOR
RECEPTOR 6" Sump Depth

TAG _____

Dimensional Data (inches and [mm]) are Subject to Manufacturing Tolerances and Change Without Notice



A- Pipe Size In.	Approx. Wt. Lbs.	Grate Open Area Sq. In.
2-3-4	20	21

ENGINEERING SPECIFICATION: ZURN Z-1750-87
12"x12"x6" deep, 14 gage, All Type 304 (CF8) Stainless Steel light duty Sani-Flor receptor with Dex-o-tex flange and non-tilt, loose set full grate with 1/2" square openings, sediment bucket, and 6" dia. x 6" high nickel bronze funnel.

OPTIONS (Check/specify appropriate options)

OUTLET (Specify type)

- ___ **IC** Inside Caulk
___ **NH** No-Hub

PIPE SIZE (Specify size)

- ___ 3",4"
___ 2" thru 4"

PREFIXES

- ___ **Z-** Type 304 (CF8) Stainless Steel*

SUFFIXES

- ___ **-HD** Cast Stainless Steel Heavy Duty Top Frame and Slotted Grate (add 1/2" to 6-9/16" Dim.)
___ **-P** 1/2" Trap Primer Connection
___ **-YS** Suspended Sediment Bucket
___ **-5** Grate w/4" Dia. x 3-3/4" High 304 S.S. Funnel
___ **-8** Grate w/8-3/8 x 3-5/8 High 304 S.S. Oval Funnel
___ **-15** Solid Cover

*REGULARLY FURNISHED UNLESS OTHERWISE SPECIFIED

REV. DATE: 10/8/93 C.N. NO. 69303

DWG. NO. P-13881 PRODUCT NO. Z-1750-87

ZURN INDUSTRIES, INC. ♦ SPECIFICATION DRAINAGE OPERATION ♦ 1801 Pittsburgh Ave. ♦ Erie, PA 16514

Phone: 814/455-0921 ♦ Fax: 814/454-7929 ♦ World Wide Web: www.zurn.com

In Canada: ZURN INDUSTRIES LIMITED ♦ 3544 Nashua Drive ♦ Mississauga, Ontario L4V1L2 ♦ Phone: 905/405-8272 Fax: 905/405-1292