



Z1200-ADJ-NUT

FLUSH WALL ADJUSTMENT NUT FOR WALL HUNG TOILET CARRIER SYSTEM

SPECIFICATION SHEET

TAG _____

Dimensional Data (inches and [mm]) are Subject to Manufacturing Tolerances and Change Without Notice

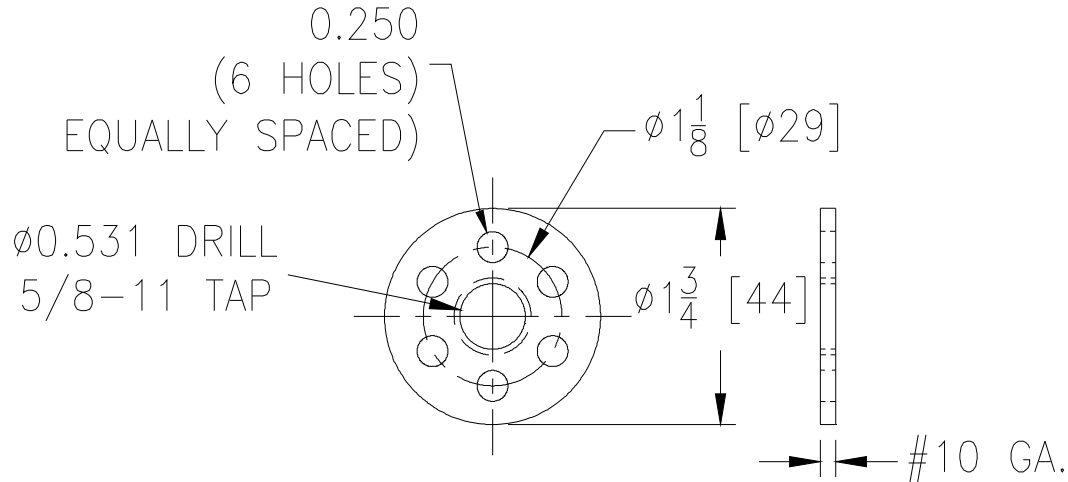

ENGINEERING SPECIFICATION: ZURN Z1200-ADJ-NUT

Ø1-3/4" [44.4mm]O.D. adjustable washer with 5/8-11 threaded I.D. Designed to simplify the installation of wall hung toilet systems. Provides rigid, uniform support of the fixture to the finished wall.

* Regularly furnished unless otherwise specified.

Zurn Industries, LLC | Specification Drainage Operation
1801 Pittsburgh Avenue, Erie, PA U.S.A. 16502 · Ph. 855-663-9876, Fax 814-454-7929
In Canada | Zurn Industries Limited
3544 Nashua Drive, Mississauga, Ontario L4V 1L2 · Ph. 905-405-8272, Fax 905-405-1292
www.zurn.com

Rev. A
Date: 02/20/15
C.N. No. 132266
Prod. | Dwg. No. Z1200-ADJ-NUT