

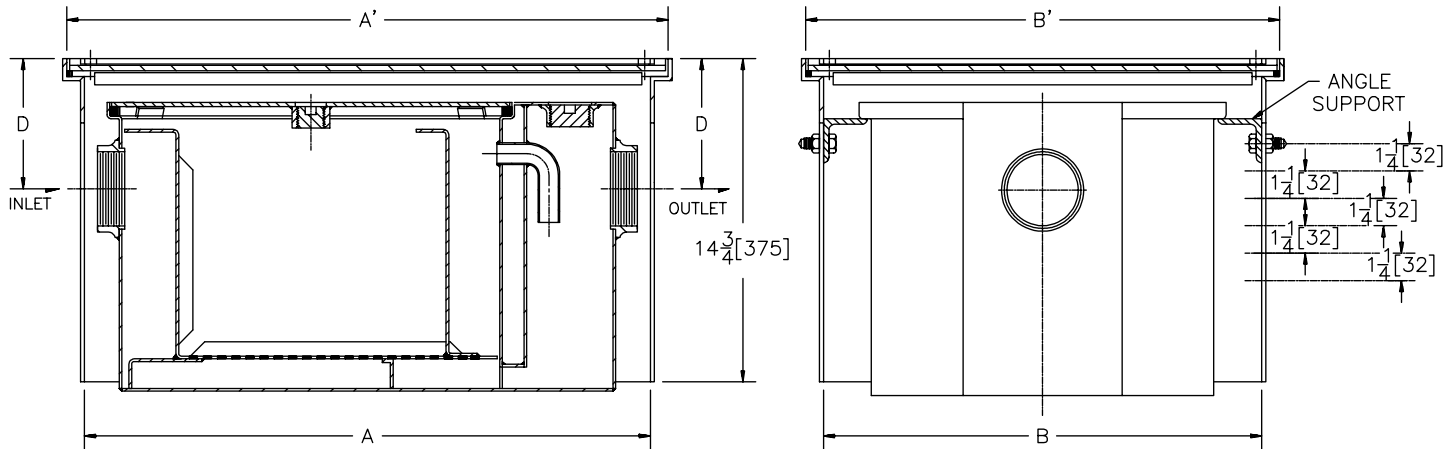

Z-1170-R-T

ADJUSTABLE RECESSING RECEIVER FOR GREASEPTOR

Dimensional Data (inches and [mm]) are Subject to Manufacturing Tolerances and Change Without Notice



| Size | Dimensions in Inches | | | | |
|------|----------------------|--------------|--------------|--------------|-------------|
| | A | A' | B | B' | D |
| 100 | 19 3/4 [502] | 21 3/4 [552] | 12 3/4 [324] | 14 3/4 [375] | 4 1/8 [105] |
| 200 | 21 3/4 [552] | 23 3/4 [603] | 15 3/8 [390] | 17 3/8 [441] | 4 3/8 [111] |
| 300 | 25 [635] | 27 [686] | 17 1/2 [444] | 19 1/2 [495] | 4 7/8 [124] |
| 400 | 25 3/4 [654] | 27 3/4 [705] | 20 [508] | 22 [559] | 5 3/8 [137] |
| 500 | 29 1/2 [749] | 31 1/2 [800] | 20 3/4 [527] | 22 3/4 [578] | 5 3/4 [146] |
| 600 | 34 [864] | 36 [914] | 23 1/4 [590] | 25 1/4 [641] | 5 7/8 [149] |
| 700 | 35 [889] | 37 [940] | 26 [660] | 28 [711] | 5 7/8 [149] |
| 800 | 37 1/4 [946] | 39 1/4 [997] | 28 [711] | 30 [762] | 6 7/8 [175] |

ENGINEERING SPECIFICATION: ZURN Z-1170-R-T Acid Resistant Epoxy Coated Recessing receiver equipped with adjustable support brackets and gasketed non-skid cover recessed for tile/terrazzo with recessed and covered lift handle. Complete with Z-1170 Greaseptor for greaseptor specifications see Z-1170 drawing.

PREFIXES

_____ Z- Acid Resistant Coated Fabricated Steel*

SUFFIXES

- _____ -K Anchor flange 1 3/4 [44] down from top and 2 [51] wide. A 3 [76] minimum extension height is required when anchor flange (-K) option is specified.
- _____ -KC Anchor flange 1 3/4 [44] down from top and 2 [51] wide with clamp collar. A 3 [76] minimum extension height is required when anchor flange (-K) option is specified.

*REGULARLY FURNISHED UNLESS OTHERWISE SPECIFIED

| | | |
|----------------|------------------------|----------------|
| REV. | DATE: 6/20/95 | C.N. NO. 72097 |
| DWG. NO. 59415 | PRODUCT NO. Z-1170-R-T | |