



Z100-321

15 [381] DIAMETER ROOF DRAIN W/ BRONZE MESH SCREEN, PERFORATED STANDPIPE, & BRONZE DOME

SPECIFICATION SHEET

TAG _____

Dimensional Data (inches and [mm]) are Subject to Manufacturing Tolerances and Change Without Notice

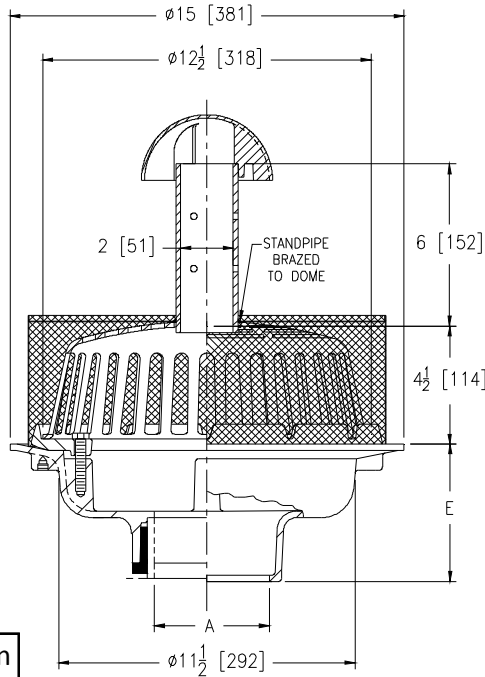

A Pipe Size In. [mm]	Approx. Wt. Lbs. [kg]	Dome Open Area Sq. In. [cm ²]
2,3,4 [51,76,102]	28 [13]	103 [665]
5,6 [127,152]	29 [13]	
8 [203]	31 [14]	

ENGINEERING SPECIFICATION: ZURN Z100-321

15" [381 mm] Diameter roof drain. Dura-Coated cast iron body with combination membrane flashing clamp/gravel guard, low silhouette bronze dome with bronze mesh screen, and 2" [51 mm] diameter bronze standpipe and dome.

OPTIONS (Check/specify appropriate options)

PIPE SIZE

- 2,3,4,6 [51,76,102,152]
- 2,3,4,6 [51,76,102,152]
- 2,3,4,6 [51,76,102,152]
- 2,3,4 [51,76,102]

(Specify size/type) **OUTLET**

- _____ IC Inside Caulk
- _____ IP Threaded
- _____ NH No-Hub
- _____ NL Neo-Loc

E BODY HT. DIM.

- 5-1/4 [133]
- 3-3/4 [95]
- 5-1/4 [133]
- 4-5/8 [117]

PREFIXES

- _____ ZRB D.C.C.I. Body with Plain Bronze Dome (3-7/8 [98] Dome height)*

SUFFIXES

- | | |
|--|--|
| _____ -AC Angular Underdeck Clamp | _____ -EB Top-Set® Adjustable Extension Assembly |
| _____ -AR Acid Resistant Epoxy Coated Finish | _____ -G Galvanized Cast Iron |
| _____ -C Underdeck Clamp | _____ -R Roof Sump Receiver |
| _____ -DP Top Set® Roof Deck Plate
(Replaces both the -C and -R) | _____ -SC Secondary Clamping Collar |
| _____ -DR Adjustable Drain Riser Extension Assembly
Adjustment from 3-5/8 [92] to 7-1/4 [184] | _____ -TC Neo-Loc Test Cap Gasket
(2,3,4 [51,76,102] NL Bottom Outlet Only) |
| _____ -E Static Extension 1 [25] thru 4 [102] (Specify Ht.) | _____ -VP Vandal-Proof Secured Top |
| _____ -EA Adjustable Extension Assembly
1-3/4 [44] thru 3-1/2 [89] | _____ -XJ Vertical Expansion Joint (See Z190) |
| | _____ -85 Stainless Steel Perforated Extension |
| | _____ -89 2 [51] High External Water Dam |
| | _____ -90 90° Threaded Side Outlet Body
(2,3,4,6 [51,76,102,152]) |

* Regularly furnished unless otherwise specified.