



Z525-79

9 [229] DIAMETER ADJUSTABLE MEDIUM DUTY DRAIN W/ HINGED SOLID COVER & SEDIMENT BUCKET

SPECIFICATION SHEET

TAG _____

Dimensional Data (inches and [mm]) are Subject to Manufacturing Tolerances and Change Without Notice

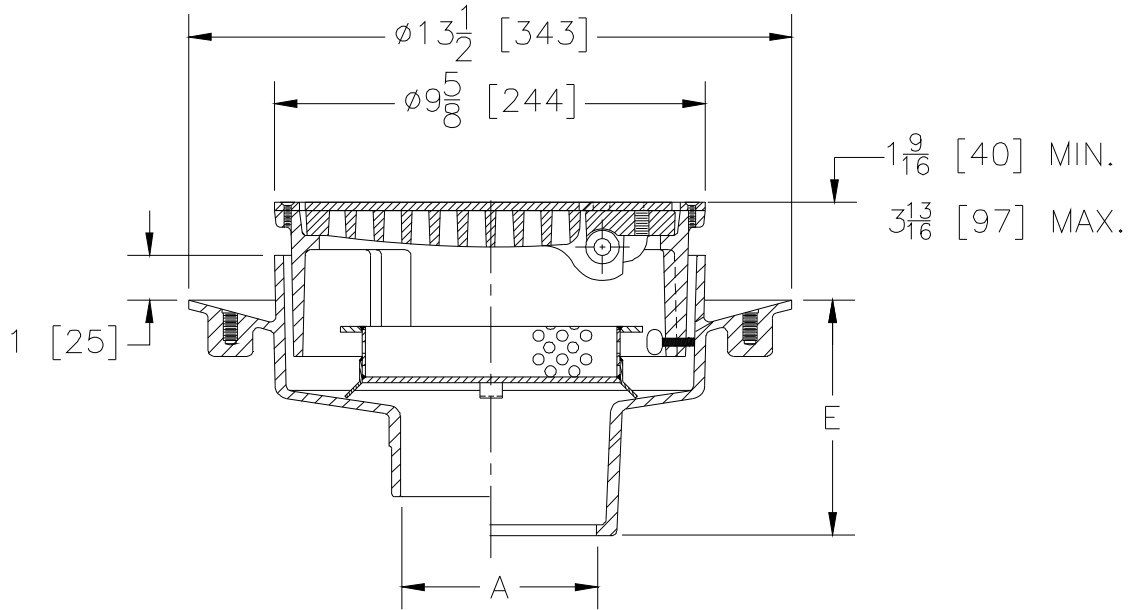

A- Pipe Size In.	Approx. Wt. Lbs. [kg]
2-3-4 [51-76-102]	35 [16]
6 [152]	35 [16]

ENGINEERING SPECIFICATION: ZURN Z525-79

9 [229] Diameter top drain, Dura-Coated cast iron body with bottom outlet, seepage pan and adjustable extension frame with medium duty cast iron deep slotted grate, nickel bronze veneer frame and solid hinged cover with suspended sediment bucket.

OPTIONS (Check/specify appropriate options)

PIPE SIZE

- 2 thru 4 [51 thru 102]
- 2 thru 4 [51 thru 102]
- 2 thru 4 [51 thru 102]
- 2 thru 4-6 [51 thru 102-152]
- 2 thru 4 [51 thru 102]

(Specify size/type) OUTLET

- _____ IC Inside Caulk
- _____ IG Inside Gasket
- _____ IP Threaded
- _____ NH No-Hub
- _____ NL Neo-Loc

'E' DIM.

- 5-1/4 [133]
- 5-1/4 [133]
- 3-1/2 [89]
- 4-1/4 [108]
- 4-3/8 [111]

PREFIXES

- _____ ZB D.C.C.I. Body with Polished Bronze Top
- _____ ZN D.C.C.I. Body with Polished Nickel Bronze Top*

SUFFIXES

- _____ -AR Acid Resisting Epoxy Coated Cast Iron
- _____ -C Clamp Collar
- _____ -G Galvanized Cast Iron
- _____ -P Trap Primer Connection
- _____ -SS Stainless Mesh Liner for Bucket
- _____ -TC Neo-Loc Test Cap Gasket
(2 [51] - 4 [102] NL Bottom Outlet Only)
- _____ -90 90° Side Outlet Body (See Z1042)

*REGULARLY FURNISHED UNLESS OTHERWISE SPECIFIED

REV.	DATE: 02/02/11	C.N. NO. 120818
DWG. NO. 304272	PRODUCT NO. Z525-79	

ZURN INDUSTRIES, LLC. ♦ SPECIFICATION DRAINAGE OPERATION ♦ 1801 Pittsburgh Ave. ♦ Erie, PA 16514

Phone: 814/455-0921 ♦ Fax: 814/454-7929 ♦ World Wide Web: www.zurn.com

In Canada: ZURN INDUSTRIES LIMITED ♦ 3544 Nashua Drive ♦ Mississauga, Ontario L4V1L2 ♦ Phone: 905/405-8272 Fax: 905/405-1292