



Z1185-99

LINT INTERCEPTOR W/ SEDIMENT BUCKET

SPECIFICATION SHEET

TAG _____

Dimensional Data (inches and [mm]) are Subject to Manufacturing Tolerances and Change Without Notice

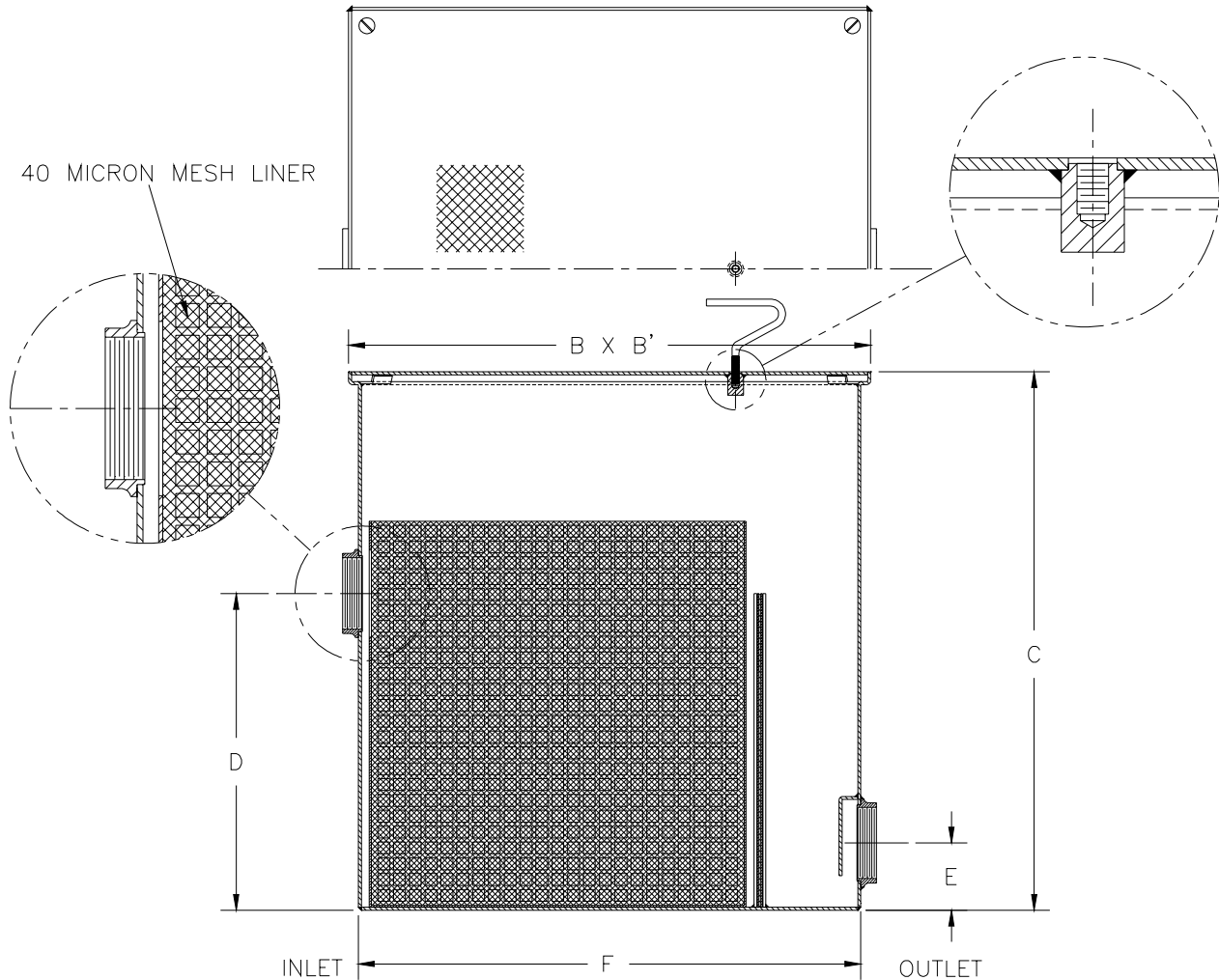

Size No. of Machines	Inlet/Outlet Size**	Flow Rate G.P.M. [L]	Approx. Wt. Lbs. [kg]	Dimensions In Inches					
				B	B'	C	D	E	F
20	4 [102]	200 [757]	500 [227]	40 [1016]	40 [1016]	35 [889]	32 [813]	4 [102]	41 [1041]
30	6 [152]	300 [1134]	810 [367]	45 [1143]	45 [1143]	40 [1016]	36 [914]	5 [127]	46 [1168]

ENGINEERING SPECIFICATION: ZURN Z1185-99 Acid Resistant Coated interior and exterior fabricated steel lint interceptor, non-skid secured aluminum cover with removable lift handle, 3/4 [19] square perforated stainless steel basket with 40 micron stainless steel mesh liner and removable stainless steel secondary screen assembly. Regularly furnished with high inlet and low outlet.

OPTIONS (Check/specify appropriate options)

PREFIXES

___ Z Acid Resistant Coated Fabricated Steel*

SUFFIXES

___ -RS Stainless Steel Screen Replacement Assembly

___ -YR Replacement Stainless Steel Basket

*REGULARLY FURNISHED UNLESS OTHERWISE SPECIFIED

REV. A	DATE 06/21/06	C.N. NO. 95241
DWG. NO. P-15227	PRODUCT NO. Z1185-99	

ZURN INDUSTRIES, INC. ♦ SPECIFICATION DRAINAGE OPERATION ♦ 1801 Pittsburgh Ave. ♦ Erie, PA 16514

Phone: 814/455-0921 ♦ Fax: 814/454-7929 ♦ World Wide Web: www.zurn.com

In Canada: ZURN INDUSTRIES LIMITED ♦ 3544 Nashua Drive ♦ Mississauga, Ontario L4V1L2 ♦ Phone: 905/405-8272 Fax: 905/405-1292