



Z415I-V

FLOOR AND SHOWER DRAIN W/ "TYPE I" STRAINER AND BACKWATER VALVE

SPECIFICATION SHEET

TAG _____

Dimensional Data (inches and [mm]) are Subject to Manufacturing Tolerances and Change Without Notice

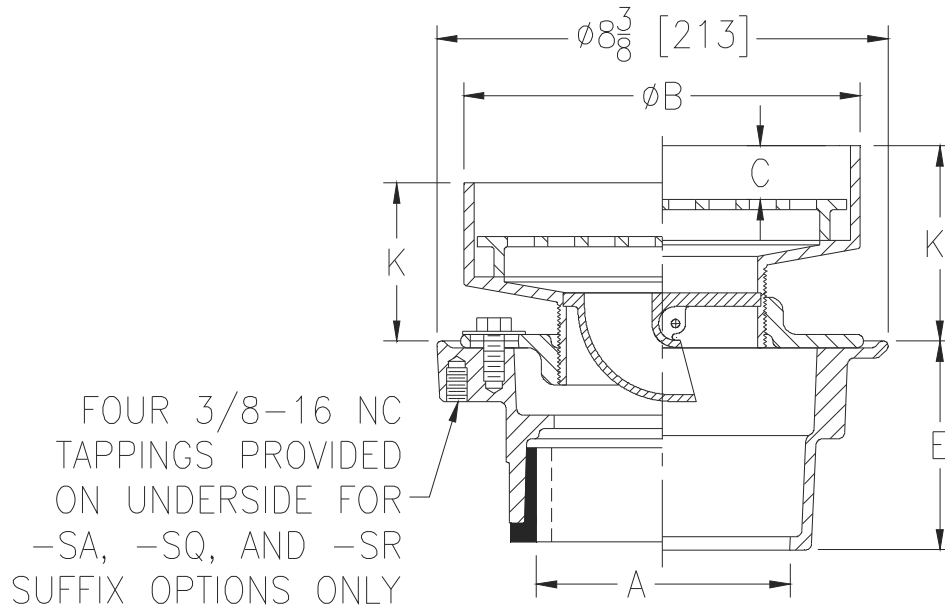

Dimensions In Inches [mm]							Approx. Wt. Lbs. [kg]	Strainer Open Area Sq. In. [cm ²]
A - Pipe Size	B Strainer Dia.	C	K		K'			
			Min.	Max.	Min.	Max.		
2,3 [51,76]	5-7/16 [138]	7/8 [22]	1-9/16 [40]	2-5/8 [67]	2-1/8 [54]	3-3/8 [86]	14 [6]	8 [52]
2,3,4 [51,76,102]	7-3/8 [187]	1 [25]	2-9/16 [65]	3-3/8 [86]	2-7/8 [73]	4-1/8 [105]	19 [9]	13 [84]
3,4 [76,102]	9 [229]	1/2 [13]	2-3/16 [56]	3-1/8 [79]	2-5/8 [67]	3-7/8 [98]	23 [10]	23 [148]
6 [152]	9 [229]	1/2 [13]	2-3/16 [56]	3-1/8 [79]	2-5/8 [67]	3-7/8 [98]	23 [10]	23 [148]

ENGINEERING SPECIFICATION: ZURN Z415I-V

Floor and shower drain, Dura-Coated cast iron body with bottom outlet, combination invertible membrane clamp and adjustable collar with seepage slots, backwater valve, and "TYPE I" polished nickel bronze strainer with raised flange.

OPTIONS (Check/specify appropriate options)

PIPE SIZE

- 2,3,4 [51,76,102]
- 2 [51]
- 3 [76]
- 4 [102]
- 6 [152]
- 2,3,4 [51,76,102]
- 2,3,4 [51,76,102]

(Specify size/type) OUTLET

- _____ IC Inside Caulk
- _____ IP Threaded
- _____ IP Threaded
- _____ IP Threaded
- _____ IP Threaded
- _____ NH No-Hub
- _____ NL Neo-Loc

E BODY HT. DIM.

- 4-3/16 [106]
- 2-7/16 [62]
- 2-3/4 [70]
- 2-13/16 [71]
- 2-7/8 [73]
- 3-13/16 [97]
- 3-7/8 [98]

PREFIXES

- _____ ZB D.C.C.I. Body with Polished Bronze Top
- _____ ZN D.C.C.I. Body with Polished Nickel Bronze Top*

SUFFIXES

- _____ -AR Acid Resistant Epoxy Coated Cast Iron
- _____ -G Galvanized Cast Iron
- _____ -P Trap Primer Connection
(Specify 1/2 [13] or 3/4 [19])
- _____ -SA Stabilizer Assembly (See Z1035)
- _____ -SQ Stabilizer Q-Deck (See Z1035-Q)
- _____ -SR Stabilizer Ring (See Z400-U)
- _____ -TC Neo-Loc Test Cap Gasket
(2,3,4 [51,76,102] NL Bottom Outlet Only)
- _____ -TS Top Secured with Slotted Screw
- _____ -U 1-3 [25-76] High Extension Adapter
- _____ -VP Vandal Proof Secured Top
- _____ -90 90° Threaded Side Outlet Body

* Regularly furnished unless otherwise specified.