



Z1188-169

SIZE 350 LARGE CAPACITY OIL INTERCEPTOR WITH INTEGRAL EXTENSION AND HEAVY-DUTY COVER

SPECIFICATION SHEET

TAG _____

Dimensional Data (inches and [mm]) are Subject to Manufacturing Tolerances and Change Without Notice

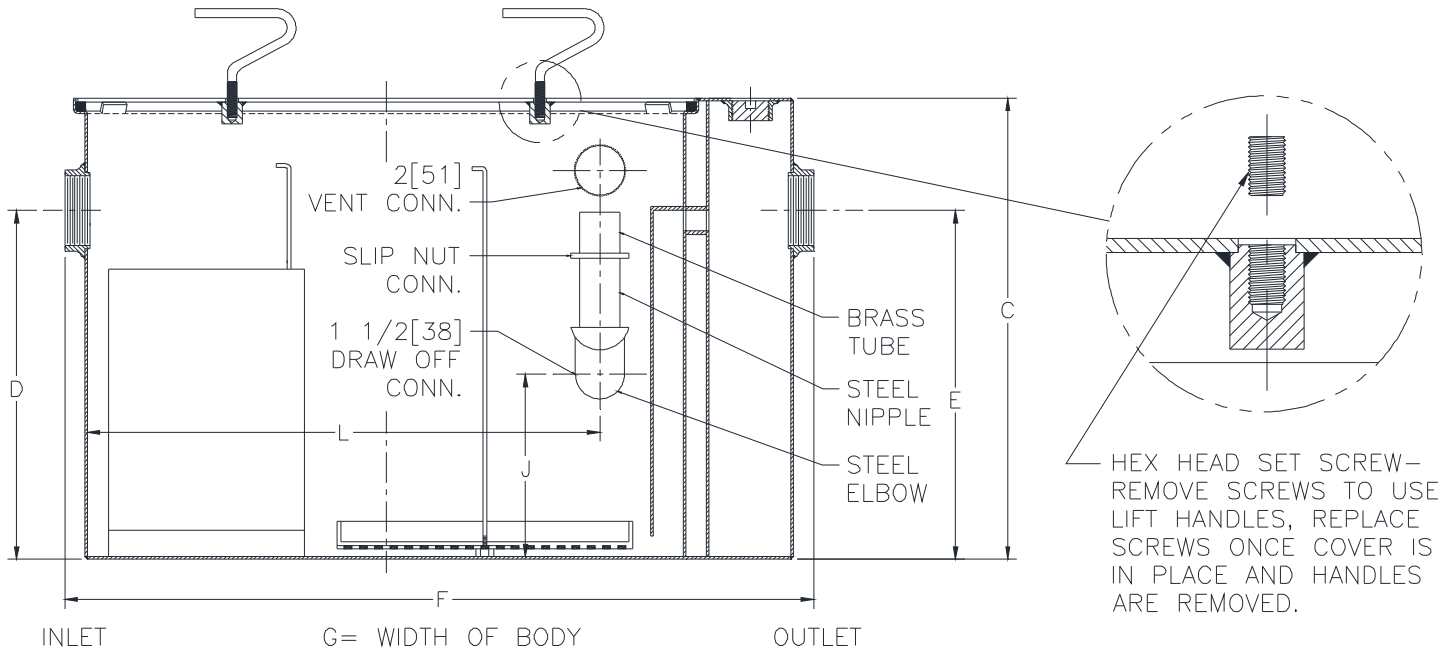

Extension Designation -E	Flow Rate G.P.M. [L/min.]	Inlet/Outlet Size	Water Capacity Gal. [L]	No. of Covers	C	D/E	F	G	J	L
E 18	350 [1325]	6 [152]	860 [3255]	2	68-1/2 [1740]	43-7/8 [1114]	87 [2210]	63-5/8 [1616]	30-3/4 [781]	74-1/8 [1883]

ENGINEERING SPECIFICATION: ZURN Z1188-169

Large capacity Acid Resistant Coated Interior and exterior fabricated steel oil interceptor with integral extension, bronze cleanout plug and visible double wall trap seal, removable combination pressure equalizing/flow diffusing baffle and sediment bucket, horizontal baffle, adjustable oil draw off and vent connections either side. Complete with secured, gasketed, non-skid heavy-duty traffic cover rated at 10,000 lbs. [4536 kg.] maximum safe live load with removable lift handles and flow control fitting. Regularly furnished with inlet and outlet in high position.

PREFIXES

___ Z Acid Resistant Coated Fabricated Steel*

SUFFIXES

___ -K Anchor Flange 1-3/4 [44] down from top and 2 [51] wide.

___ -KC Anchor Flange 1-3/4 [44] down from top and 2 [51] wide with clamp collar.

* Regularly furnished unless otherwise specified.

Zurn Industries, LLC | Specification Drainage Operation
 1801 Pittsburgh Avenue, Erie, PA U.S.A. 16502 · Ph. 855-663-9876, Fax 814-454-7929
 In Canada | Zurn Industries Limited
 3544 Nashua Drive, Mississauga, Ontario L4V 1L2 · Ph. 905-405-8272, Fax 905-405-1292
www.zurn.com

Rev. -
 Date: 12/20/2016
 C.N. No. 135836
 Prod. | Dwg. No. Z1188-169