

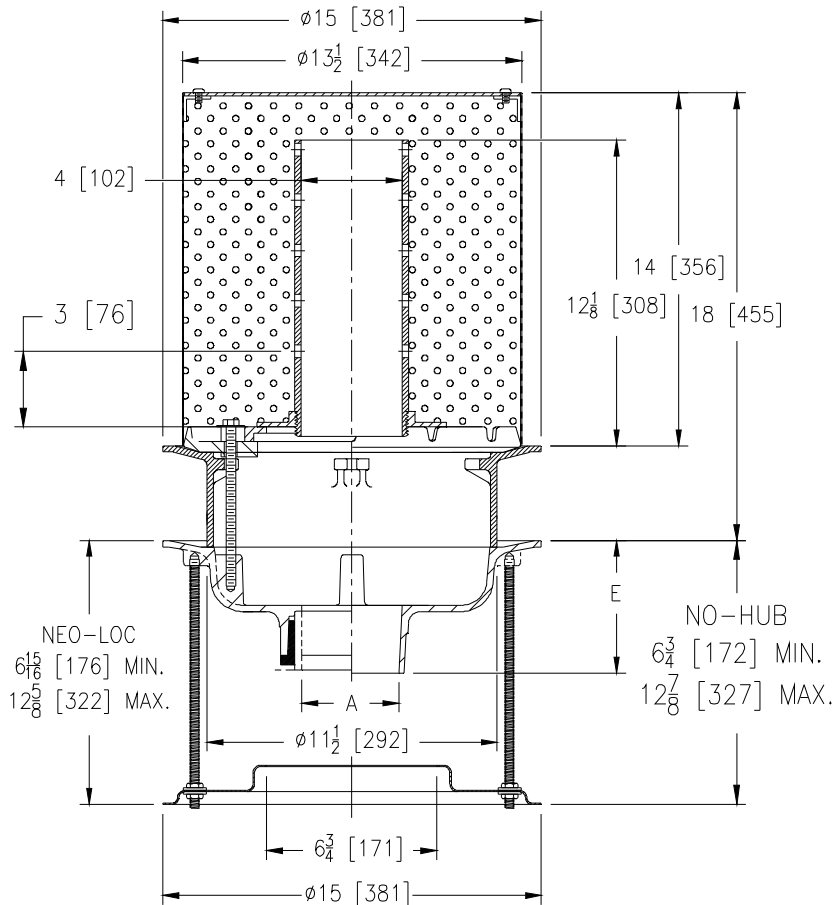

Z100-333

15 [381] DIAMETER MAIN ROOF DRAIN W/ PERFORATED STANDPIPE, GRAVEL GUARD, STABILIZER ASSEMBLY & 4 [102] WATER DAM FOR 6 [152] OUTLET **SPECIFICATION SHEET**
TAG _____

Dimensional Data (inches and [mm]) are Subject to Manufacturing Tolerances and Change Without Notice



A Pipe Size In.[mm]	Approx. Wt. Lbs. [kg]
6 [152]	36 [16]

ENGINEERING SPECIFICATION: ZURN Z100-333

15" [381mm] Diameter roof drain. Dura-Coated cast iron body with combination membrane flashing clamp/gravel guard, 4" [102mm] standpipe, stainless steel perforated gravel guard with solid secured top, 4" [102mm] water dam, and stabilizer assembly for 6" [152mm] outlet.

OPTIONS (Check/specify appropriate options)

PIPE SIZE

6 [152]
6 [152]

(Specify size/type) **OUTLET**

____ NH No-Hub
____ NL Neo-Loc

E BODY HT. DIM.

5-1/4 [133]
5-7/16 [138]

PREFIXES

____ Z D.C.C.I. Body

SUFFIXES

____ -AR Acid Resistant Epoxy Coated
 ____ -DX Dex-o-tex Flange
 ____ -G Galvanized Cast Iron
 ____ -R Roof Sump Receiver
 ____ -SC Secondary Clamp Collar
 ____ -VP Vandal-Proof Secured Top

* Regularly furnished unless otherwise specified.