

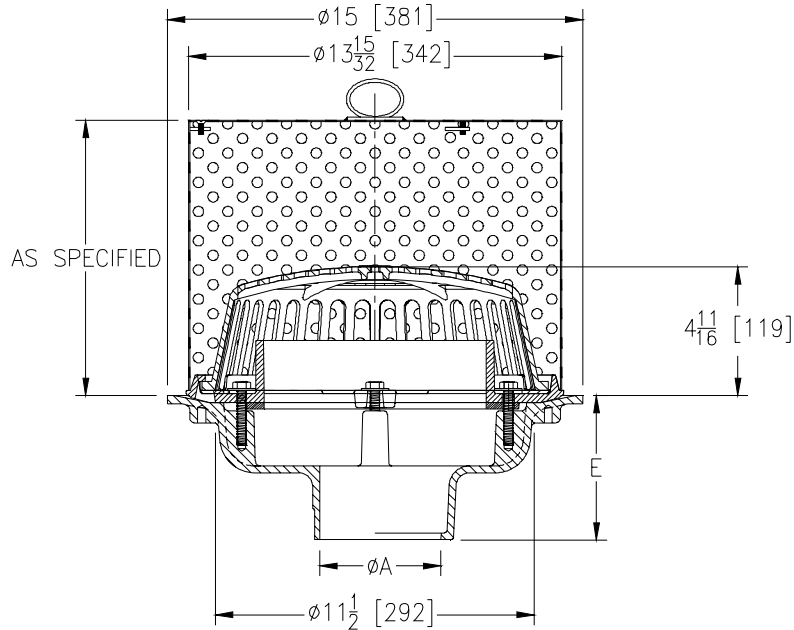

Z100-237

15 [381] DIAMETER ROOF DRAIN W/ COVERED, PERFO- RATED GRAVEL GUARD, LIFT RING, AND 2 [51] INTERNAL WATER DAM SPECIFICATION SHEET TAG _____

Dimensional Data (inches and [mm]) are Subject to Manufacturing Tolerances and Change Without Notice



A Pipe Size In.	Approx. Wt. Lbs. [kg]	Dome Open Area Sq. In. [cm ²]
2,3,4 [51,76,102]	26 [12]	103 [665]
5,6 [127,152]	27 [12]	
8 [203]	28 [13]	

ENGINEERING SPECIFICATION: ZURN Z100-237

15 [381] Diameter roof drain. Dura-Coated cast iron body with combination membrane flashing clamp/gravel guard with 2 [51] internal water dam, covered perforated stainless steel gravel guard with lift ring, and a low silhouette Poly-Dome strainer.

PIPE SIZE

2 thru 6,8 [51 thru 152,203]
 2 thru 6,8 [51 thru 152,203]
 2 thru 6,8 [51 thru 152,203]
 2,3,4 [51,76,102]
 6 [152]

(Specify size/type) OUTLET

____ IC Inside Caulk
 ____ IP Threaded
 ____ NH No-Hub
 ____ NL Neo-Loc
 ____ NL Neo-Loc

E BODY HT. DIM.

5 1/4 [133]
 3 3/4 [95]
 5 1/4 [133]
 4 9/16 [116]
 5 7/16 [112]

PREFIXES

____ Z D.C.C.I. Body with Poly-Dome*
 ____ ZA D.C.C.I. Body with Aluminum Dome
 ____ ZC D.C.C.I. Body with Cast Iron Dome
 ____ ZRB D.C.C.I. Body with Plain Bronze Dome

SUFFIXES

____ -AC Angular Underdeck Clamp
 ____ -AR Acid Resistant Epoxy Coated
 ____ -C Underdeck Clamp
 ____ -DE Deck Extension-E
 ____ -DP Top-Set® Deck Plate (Replaces both the -C and -R)
 ____ -DR Top-Set® Drain Riser
 ____ -DX Dex-o-tex Flange
 ____ -E Static Extension 1 [25] thru 4 [102] (Specify Ht.)
 ____ -EA Adjustable Extension Assembly
 2 1/8 [54] thru 3 1/2 [89]
 ____ -EB Top-Set® Adjustable Extension Assembly
 ____ -G Galvanized Cast Iron
 ____ -GD Galvanized Cast Iron Dome (ZC Only)
 ____ -HD 6 3/4 [171] High Aluminum Dome Strainer
 (148 Sq. In. [955 cm²] Open Area) (ZA Only)
 ____ -R Roof Sump Receiver
 ____ -SC Secondary Clamp Collar

____ -ST Dome with Solid Top (ZA, ZC & ZRB Only)
 ____ -TC Neo-Loc Test Cap Gasket
 (2 - 4 [51 - 102] NL Bottom Outlet Only)
 ____ -VP Vandal-Proof Secured Top
 ____ -90 90° Threaded Side Outlet
 (2 thru 6 [51 thru 152])

*REGULARLY FURNISHED UNLESS OTHERWISE SPECIFIED

REV. DATE: 6/15/2011 C.N. NO. 121423

DWG. NO. 306282 PRODUCT NO. Z100-237

ZURN INDUSTRIES, LLC ♦ SPECIFICATION DRAINAGE OPERATION ♦ 1801 Pittsburgh Ave. ♦ Erie, PA 16514

Phone: 814/455-0921 ♦ Fax: 814/454-7929 ♦ World Wide Web: www.zurn.com

In Canada: ZURN INDUSTRIES LIMITED ♦ 3544 Nashua Drive ♦ Mississauga, Ontario L4V1L2 ♦ Phone: 905/405-8272 Fax: 905/405-1292