



Z100-241

15 [381] DIAMETER ROOF DRAIN W/SECURED DOME W/
4 [102] NO-HUB STANDPIPE, STAINLESS STEEL MESH
OVER DOME, AND Z181-HD-SS UPPER DRAIN

SPECIFICATION SHEET

TAG _____

Dimensional Data (inches and [mm]) are Subject to Manufacturing Tolerances and Change Without Notice

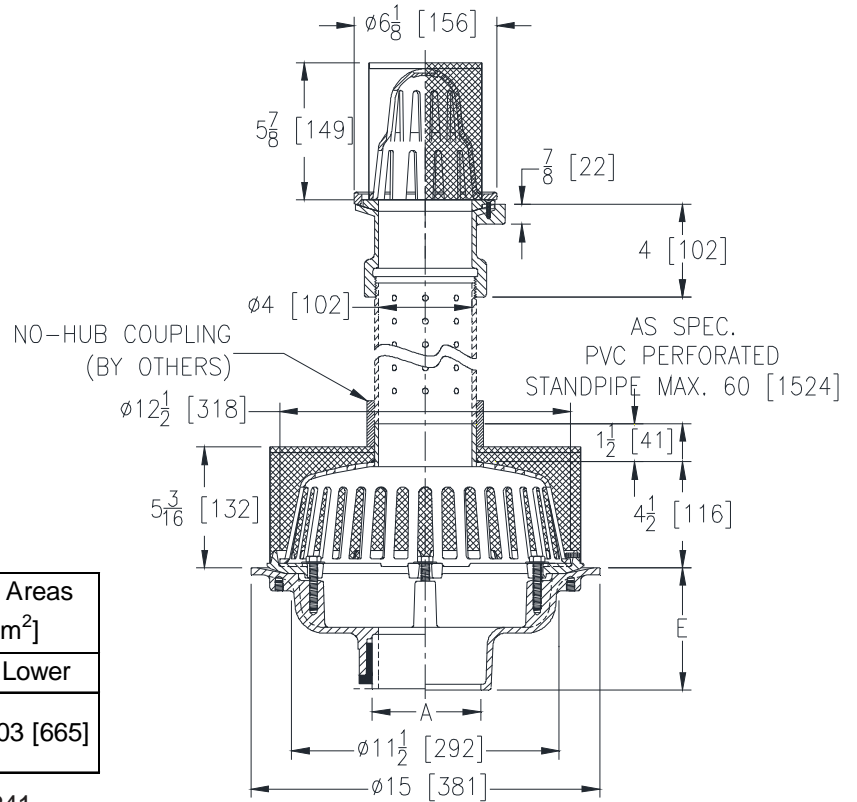

A - Pipe Size Inches [mm]	Approx. Wt. Lbs. [kg]	Dome Open Areas Sq. In. [cm ²]	
		Upper	Lower
2, 3, 4 [51, 76, 102]	26 [12]	20 [129]	103 [665]
6 [152]	27 [12]		
8 [203]	28 [13]		

ENGINEERING SPECIFICATION: ZURN Z100-241

15" [381mm] Diameter roof drain. Dura-Coated cast iron body with combination membrane flashing clamp/gravel guard, low silhouette secured dome with stainless steel mesh liner, 4" [102mm] PVC No-Hub stand pipe, and Z181-HD-SS upper drain assembly.

OPTIONS (Check/specify appropriate options)

PIPE SIZE

- 3, 4, 6 [76, 102, 152]
- 2, 3, 4, 6, 8 [51, 76, 102, 152, 203]
- 2, 3, 4, 6, 8 [51, 76, 102, 152, 203]
- 2, 3, 4 [51, 76, 102]
- 6 [152]

(Specify size/type) OUTLET

- ___ IC Inside Caulk
- ___ IP Threaded
- ___ NH No-Hub
- ___ NL Neo-Loc
- ___ NL Neo-Loc

'E' BODY HT. DIM.

- 5-1/4 [133]
- 3-3/4 [95]
- 5-1/4 [133]
- 4-9/16 [116]
- 5-7/16 [112]

PREFIXES

- ___ ZRB D.C.C.I. Body with Plain Bronze Dome*
- ___ ZB D.C.C.I. Body with Polished Bronze Dome
- ___ ZN D.C.C.I. Body with Polished Nickel Bronze Dome

SUFFIXES

- ___ -AC Angular Underdeck Clamp
- ___ -AR Acid Resistant Epoxy Coated
- ___ -C Underdeck Clamp
- ___ -DE Deck Extension
- ___ -DP Top-Set® Deck Plate (Replaces both the -C and -R)
- ___ -DR Top-Set® Drain Riser
- ___ -E Static Extension 1 [25] thru 4 [102] (Specify Ht.)
- ___ -EB Top-Set® Adjustable Extension Assembly
- ___ -G Galvanized Cast Iron
- ___ -R Roof Sump Receiver
- ___ -SC Secondary Clamp Collar
- ___ -SS Stainless Steel Mesh Over Stand Pipe
- ___ -ST Dome with Solid Top (ZA & ZC Only)
- ___ -TC Neo-Loc Test Cap Gasket (2,3,4 [51,76,102] NL Bottom Outlet Only)
- ___ -VP Vandal-Proof Secured Top
- ___ -90 90° Threaded Side Outlet Body (2,3,4,6 [51,76,102,152])

* Regularly furnished unless otherwise specified.