



Z100-381

15 [381] DIAMETER MAIN ROOF DRAIN W/ 2 [51] HIGH EXTERNAL WATER, MESH SCREEN, STANDPIPE AND UPPER Z100-FG

SPECIFICATION SHEET

TAG _____

Dimensional Data (inches and [mm]) are Subject to Manufacturing Tolerances and Change Without Notice

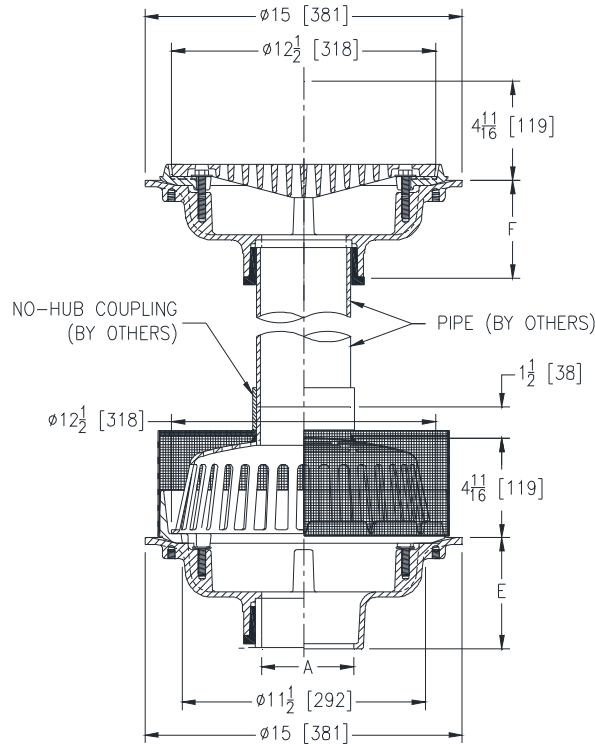

A Pipe Size Inches [mm]	Approx. Wt. Lbs. [kg]	Dome Open Area Sq. In. [cm ²]
2,3,4 [51, 76, 102]	54 [24]	32 [206]
6 [152]	52 [24]	
8 [203]	53 [24]	

ENGINEERING SPECIFICATION: ZURN Z100-381

15" [381mm] Diameter roof drain. Dura-Coated cast iron body with 2 [51] combination membrane flashing clamp/gravel guard, low silhouette cast iron dome, stainless mesh screen, no-hub coupling on lower body, and standpipe (by others) and upper Z100-FG.

OPTIONS (Check/specify appropriate options)

PIPE SIZE

3,4,6 [76,102,152]

2,3,4,6,8 [51,76,102,152,203]

2,3,4,6,8 [51,76,102,152,203]

2,3,4 [51,76,102]

6 [152]

(Specify size/type) OUTLET

_____ IC Inside Caulk

_____ IP Threaded

_____ NH No-Hub

_____ NL Neo-Loc

_____ NL Neo-Loc

'E' BODY HT. DIM.

5-1/4 [133]

3-3/4 [95]

5-1/4 [133]

4-9/16 [116]

5-7/16 [112]

'F' BODY HT. DIM.

-

-

-

4-9/16 [116]

5-7/16 [112]

PREFIXES

___ Z D.C.C.I. Body with Grate*

SUFFIXES

___ -AC Angular Underdeck Clamp (Lower Body)

___ -AR Acid Resistant Epoxy Coated

___ -C Underdeck Clamp (Lower Body)

___ -DX Dex-O-Tex Flange

___ -G Galvanized Cast Iron

___ -GD Galvanized Cast Iron Dome (Lower Body)

___ -R Roof Sump Receiver (Lower Body)

___ -SC Secondary Clamp Collar

___ -TC Neo-Loc Test Cap Gasket (Lower Body)

(2,3,4 [51,76,102] NL Bottom Outlet Only)

___ -VP Vandal-Proof Secured Top

___ -84 Stainless Steel Perforated Gravel Guard

___ -89 2 [51] High External Water Dam (Upper Body)

___ -90 90° Threaded Side Outlet Body

(2,3,4,6 [51,76,102,152]) (Lower Body)

* Regularly furnished unless otherwise specified.

Zurn Industries, LLC | Specification Drainage Operation
1801 Pittsburgh Avenue, Erie, PA U.S.A. 16502 · Ph. 855-663-9876, Fax 814-454-7929

In Canada | Zurn Industries Limited
7900 Goreway Drive, Unit 10, Brampton, Ontario L6T 5W6, 877-892-5216

www.zurn.com

Rev. -
Date: 04/27/2020
C.N. No. 142630
Prod. | Dwg. No. Z100-381