



Z662-HP-VP

16 [406] SQUARE TOP HEAVY-DUTY DRAIN
W/ VANDAL-PROOF, HEEL-PROOF GRATE

SPECIFICATION SHEET

TAG _____

Dimensional Data (inches and [mm]) are Subject to Manufacturing Tolerances and Change Without Notice

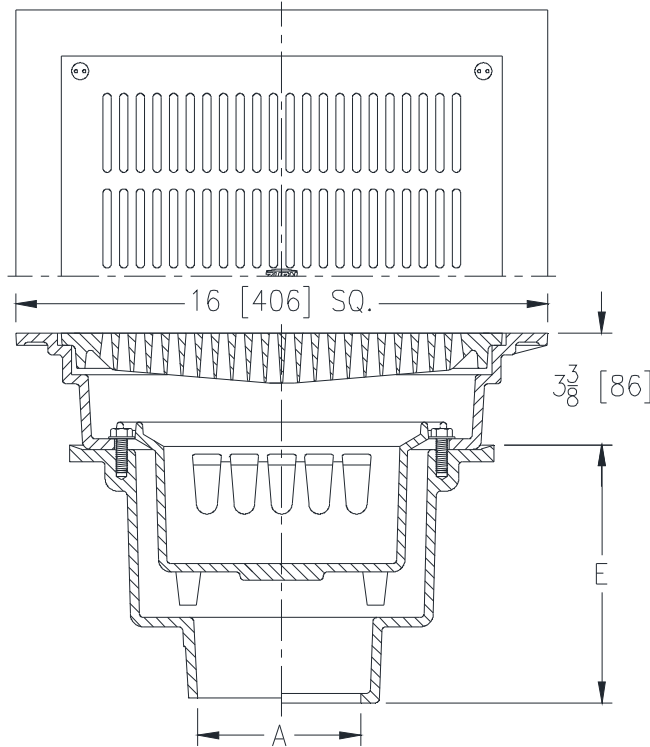

A Pipe Size In. [mm]	Approx. Wt. Lbs. [kg]	Grate Open Area Sq. In. [cm ²]
3, 4 [76, 102]	95 [43]	51 [329]
6 [152]	98 [44]	

ENGINEERING SPECIFICATION: Z662-HP-VP

16" [406mm] Square top drain, Dura-Coated cast iron body with bottom outlet, seepage pan and combination membrane flashing clamp and frame for secured, vandal-proof, heavy-duty, heel-proof grate with suspended sediment bucket.

OPTIONS (Check/specify appropriate options)

PIPE SIZE

- ___ 4, 6 [102, 152]
- ___ 4, 6 [102, 152]
- ___ 4, 6 [102, 152]
- ___ 3, 4, 6 [76, 102, 152]
- ___ 3, 4 [76, 102]

(Specify size/type) OUTLET

- ___ IC Inside Caulk
- ___ IG Inside Caulk
- ___ IP Threaded
- ___ NH No-Hub
- ___ NL Neo-Loc

'E' BODY HT. DIM.

- ___ 7-3/4 [197]
- ___ 7-3/4 [197]
- ___ 6-5/16 [160]
- ___ 7-13/16 [198]
- ___ 7-3/16 [183]

PREFIXES

- ___ Z D.C.C.I. Body and Top*
- ___ ZB D.C.C.I Body w/ Polished Bronze Top (Add 3/16 [5] to 3-3/8 [86] and 11/16 [17] to 16 [406] Dim.)
- ___ ZN D.C.C.I Body w/ Polished Nickel Bronze Top (Add 3/16 [5] to 3-3/8 [86] and 11/16 [17] to 16 [406] Dim.)

SUFFIXES

- ___ -DG Duresist Grate
- ___ -G Galvanized Cast Iron
- ___ -LY (Less) Sediment Bucket
- ___ -PK Precast Kit
- ___ -SS Stainless Mesh Liner for Bucket
- ___ -TC Neo-Loc Test Cap Gasket (3 [76] , 4 [102] NL Bottom Outlet Only)
- ___ -YA Aluminum Sediment Bucket

* Regularly furnished unless otherwise specified.