



# Z550-D

9 [229] DIAMETER MEDIUM  
DUTY DRAIN W/ DOME GRATE

SPECIFICATION SHEET

TAG \_\_\_\_\_

Dimensional Data (inches and [ mm ]) are Subject to Manufacturing Tolerances and Change Without Notice

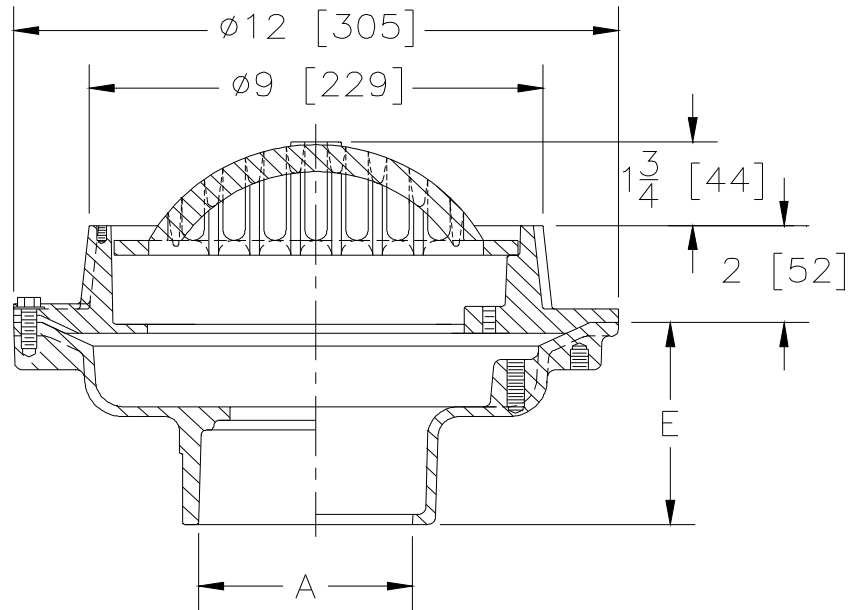

A- Pipe Size In.[mm]	Approx. Wt. Lbs.[kg]	Dome Open Area Sq. In.[cm <sup>2</sup> ]
2,3,4,6[76,102]	16 [7]	14 [90]

**ENGINEERING SPECIFICATION: ZURN Z550-D**

9" [229mm] Diameter top drain, Dura-Coated cast iron body with bottom outlet, seepage pan and dome grate, and combination membrane flashing clamp and frame.

**OPTIONS** (Check/specify appropriate options)

**PIPE SIZE**

- 3,4 [76,102]
- 3,4 [76,102]
- 3,4 [76,102]
- 2,3,4 [51,76,102]
- 6 [152]
- 2,3,4 [51,76,102]

(Specify size/type) **OUTLET**

- \_\_\_ IC Inside Caulk
- \_\_\_ IG Inside Gasket
- \_\_\_ IP Threaded
- \_\_\_ NH No-Hub
- \_\_\_ NH No-Hub
- \_\_\_ NL Neo-Loc

**'E' BODY HT. DIM.**

- 3-3/4 [95]
- 3-3/4 [95]
- 2-3/4 [70]
- 4-3/4 [121]
- 5-1/4 [133]
- 3-1/2 [89]

**PREFIXES**

- \_\_\_ Z D.C.C.I. Body and Top\*

**SUFFIXES**

- \_\_\_ -AR Acid Resisting Epoxy Coated Cast Iron
- \_\_\_ -G Galvanized Cast Iron
- \_\_\_ -P Trap Primer Connection
- \_\_\_ -S Secondary Strainer
- \_\_\_ -SS Stainless Mesh Liner for Bucket
- \_\_\_ -TC Neo-Loc Test Cap Gasket
- \_\_\_ -TS Top Secured with Slotted Screws
- \_\_\_ -VP Vandal Proof Secured Top
- \_\_\_ -Y Sediment Bucket
- \_\_\_ -90 90° Threaded Side Outlet Body (3,4 [76,102])

\* Regularly furnished unless otherwise specified.