



Z-100-108

TAG _____

**15" DIAMETER ROOF DRAIN WITH STATIC
EXTENSION AND INDIRECT WASTE FUNNEL**

Dimensions Subject to Manufacturing Tolerances

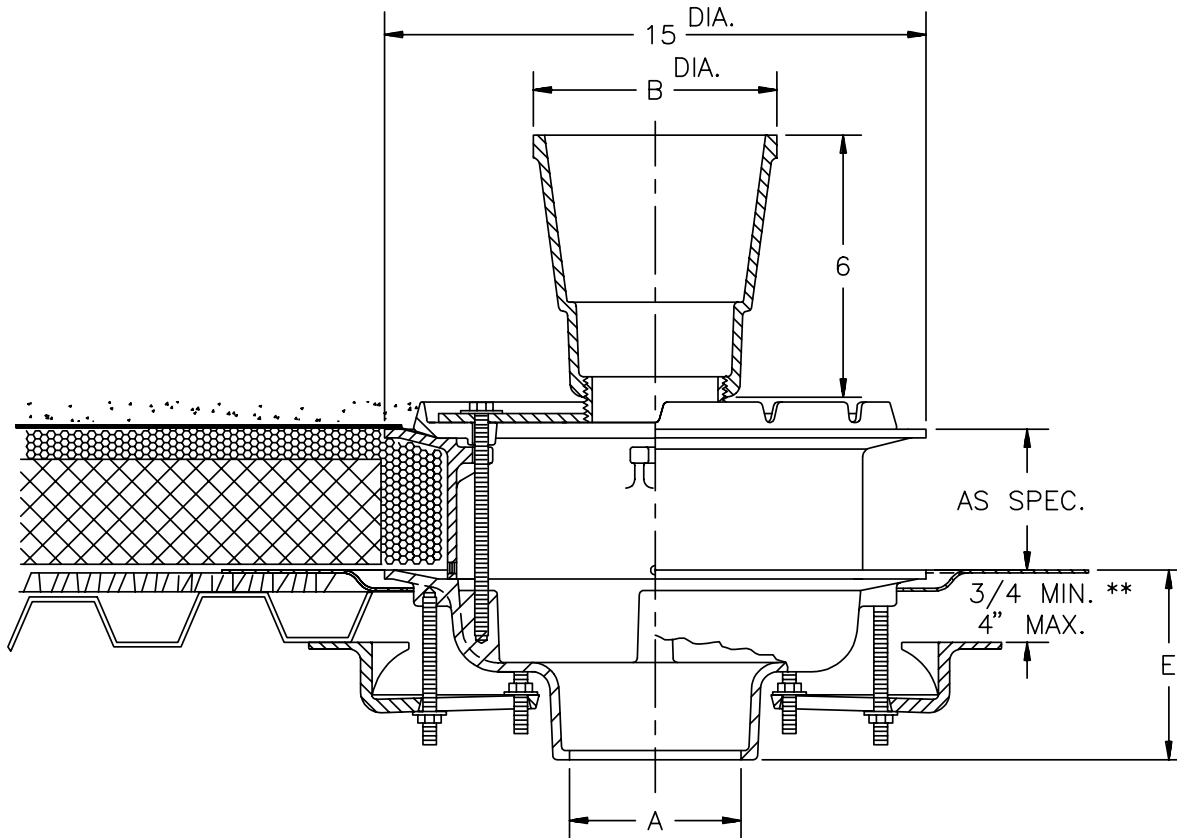

A- Pipe Size In.	B	Approx. Wt. Lbs.
2-3	6-3/4	49
4	8-5/8	

ENGINEERING SPECIFICATION: ZURN Z-100-108-C-E-R
15" Diameter roof drain. Galvanized cast iron body, static extension, roof sump receiver, under deck clamp, combination membrane flashing clamp/gravel guard securing plate and indirect waste funnel.

OPTIONS (Check/specify appropriate options)

OUTLET

_____ **IC** Inside Caulk

PIPE SIZE (Specify size)

_____ 2" thru 4"

**'E' BODY HT.
DIMENSION**

5-1/4

PREFIXES

_____ **Z-** D.C.C.I. Body and Funnel*
_____ **ZRB-** D.C.C.I. Body with Plain Bronze Funnel

SUFFIXES

_____ **-AC** Angular Underdeck Clamp
_____ **-DB** Bottom Dome Strainer
_____ **-DX** Dex-o-Tex Flange
_____ **-EA** Adjustable Extension Assembly 1-3/4" thru 3-1/2"
_____ **-G** Galvanized Cast Iron
_____ **-S** Secondary Strainer
_____ **-VP** Vandal Proof Secured Top
_____ **-84** Stainless Steel Perforated Gravel Guard
_____ **-85** Stainless Steel Perforated Extension
_____ **-89** 2" High External Water Dam

REV.	DATE: 1/8/92	C.N. NO. 68030
DWG. NO. P-13662 PRODUCT NO. Z-100-108		

*REGULARLY FURNISHED UNLESS OTHERWISE SPECIFIED

ZURN INDUSTRIES, INC. ♦ SPECIFICATION DRAINAGE OPERATION ♦ 1801 Pittsburgh Ave. ♦ Erie, PA 16514
Phone: 814/455-0921 ♦ Fax: 814/454-7929 ♦ World Wide Web: www.zurn.com

In Canada: ZURN INDUSTRIES LIMITED ♦ 3544 Nashua Drive ♦ Mississauga, Ontario L4V1L2 ♦ Phone: 905/405-8272 Fax: 905/405-1292