



Z645-77

13 5/8 x 12 1/2 [346 x 318] HEAVY-DUTY DRAIN W/ 8 [203] NO-HUB

SPECIFICATION SHEET

TAG _____

Dimensional Data (inches and [mm]) are Subject to Manufacturing Tolerances and Change Without Notice

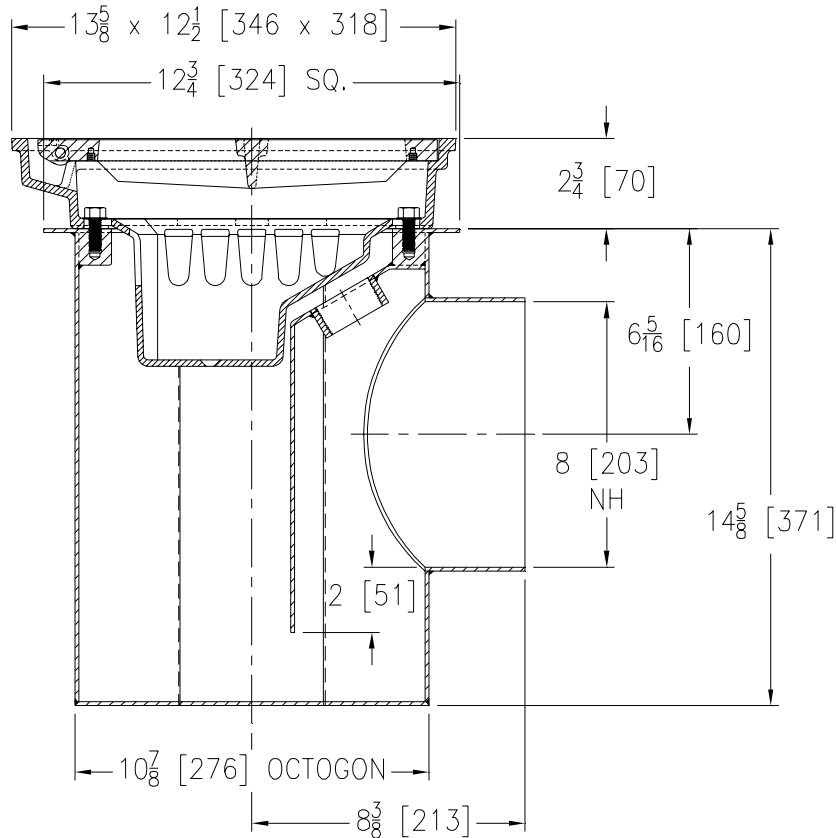

Approx. Wt. Lbs. [kg]	Grate Open Area Sq. In. [cm ²]
118 [54]	44 [284]

ENGINEERING SPECIFICATION: Zurn Z645-77

13 5/8 x 12 1/2 [346 x 318] Square top drain, acid resistant epoxy coated fabricated steel body with 8 [203] No-Hub side outlet, internal trap with bronze cleanout plug, Dura-Coated cast iron seepage pan and combination membrane flashing clamp and frame for cast iron hinged heavy-duty slotted grate with suspended sediment bucket.

OPTIONS (Check/specify appropriate options)

PIPE SIZE

8 [203]

OUTLET

_____ NH No-Hub

PREFIXES

- _____ Z A.R.C. Fabricated Steel Body and D.C.C.I. Top*
- _____ ZB A.R.C. Fabricated Steel Body w/ Polished Bronze Top
(Add 3/16 [5] to 2 3/4 [70] and 11/16 [17] to 12 1/2 [318] and 13 5/8 [346] Dims.)
- _____ ZN A.R.C. Fabricated Steel Body w/ Polished Nickel Bronze Top
(Add 3/16 [5] to 2 3/4 [70] and 11/16 [17] to 12 1/2 [318] and 13 5/8 [346] Dims.)

SUFFIXES

- _____ -AR Acid Resistant Epoxy Coated Cast Iron
- _____ -DG Duresist Grate
- _____ -G Galvanized Cast Iron
- _____ -HL Hinged Locking Grate
- _____ -P Trap Primer Connection
- _____ -TS Top Secured with Slotted Screws
- _____ -VP Vandal-Proof Secured Top
- _____ -YA Aluminum Sediment Bucket

*REGULARLY FURNISHED UNLESS OTHERWISE SPECIFIED

REV.	DATE: 04/25/06	C.N. NO. 95055
DWG. NO. P-15272	PRODUCT NO. Z645-77	