



Z187-97

4 X 18 1/2 [102 X 470] SCUPPER DRAIN W/ 45° BOTTOM OUTLET & FLUSH GRATE

SPECIFICATION SHEET

TAG _____

Dimensional Data (inches and [mm]) are Subject to Manufacturing Tolerances and Change Without Notice

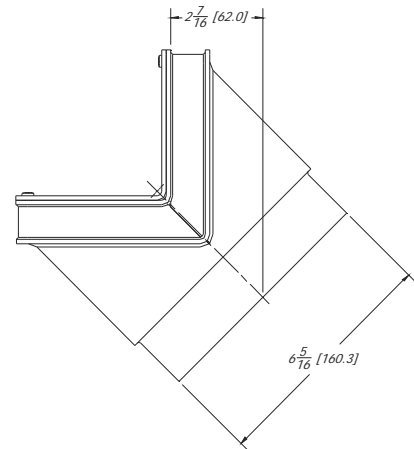
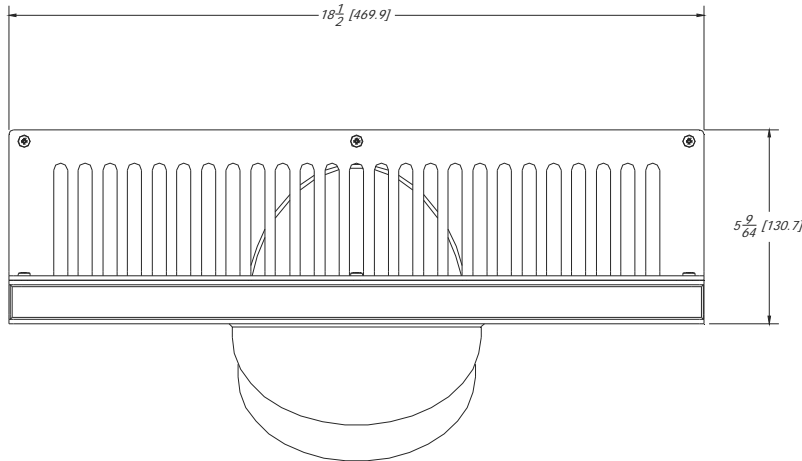

A-Pipe Size Inches	Approx. Wt. Lbs. [kg]	Grate Open Area Sq. In. [cm ²]
6 [152]	11 [5]	33 [212]

ENGINEERING SPECIFICATION: ZURN Z187-97

4 x 18 1/2 [102 x 470] Scupper drain, stainless steel body with 45° bottom outlet, and flush vandal proof, secured stainless steel grate .

OPTIONS (Check/specify appropriate options)

PIPE SIZE _____ (Specify size/type) **OUTLET**

6 [150] _____ NH No-Hub

PREFIXES

_____ ZS Stainless Steel Body with Grate*

SUFFIXES

_____ -TS Secured Top With Slotted Screws

* Regularly furnished unless otherwise specified.