



Z1471-83
AIR INLET FOR 15 [381] PIPE

SPECIFICATION SHEET

TAG _____

Dimensional Data (inches and [mm]) are Subject to Manufacturing Tolerances and Change Without Notice

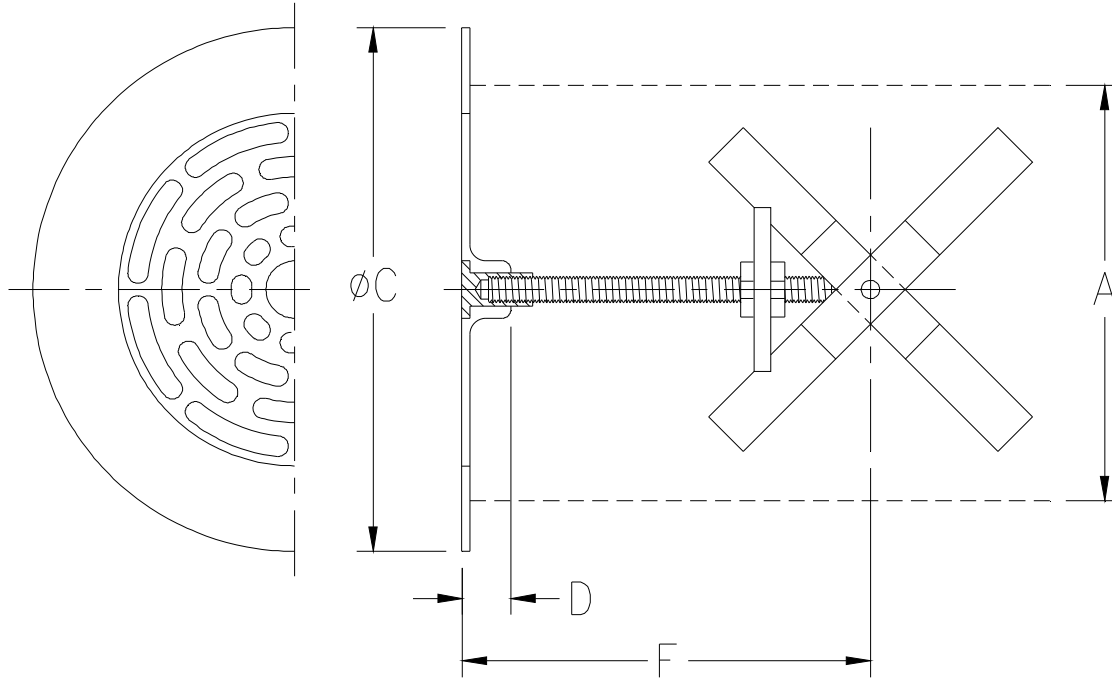

Dimensions in Inches [mm]				Approx. Wt. Lbs. [kg]	Open Area Sq. In. [cm ²]
A - Pipe Size	C	D	F		
15 [381]	20 [508]	3/4 [19]	6-1/4 [159]	11 [5]	70 [452]

ENGINEERING SPECIFICATION: ZURNZS1471-83

Fresh air inlet for 15" [381mm] pipe. Perforated stainless steel, complete with 4-point contact locking device.

OPTIONS (Check/specify appropriate options)

PREFIXES

___ ZS Stainless Steel *

* Regularly furnished unless otherwise specified.