



Z415D-PC

FLOOR AND SHOWER DRAIN W/ "TYPE D" STRAINER AND PROTECTIVE COVER

SPECIFICATION SHEET

TAG _____

Dimensional Data (inches and [mm]) are Subject to Manufacturing Tolerances and Change Without Notice

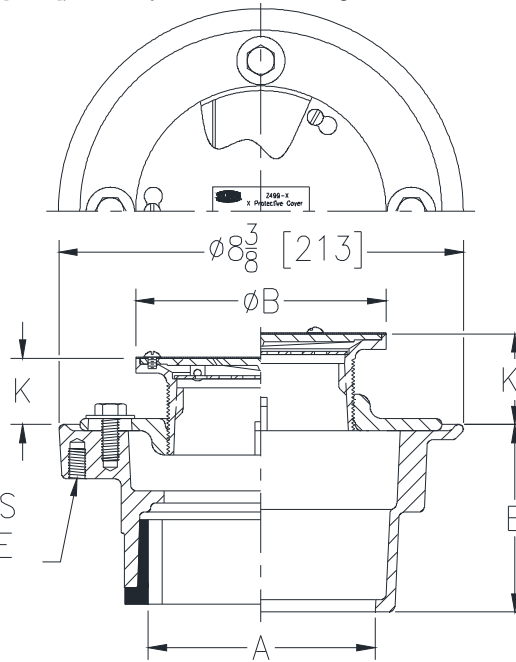

FOUR $\frac{3}{8}$ -16 NC TAPPINGS PROVIDED ON UNDERSIDE FOR -SA, -SQ, & -SR SUFFIX OPTIONS ONLY

Dimensions in In [mm]						Approx Wt. lbs [kg]
A Pipe Size	B Strainer Dia.	K		K'		
		Min	Max	Min	Max	
2,3 [51,76]	5 [127]	1 [25]	1-1/2 [38]	1-3/32 [28]	2-1/4 [57]	12 [5]
2,3,4 [51,76,102]	6 [152]		1-25/32 [45]	1-13/32 [36]	2-17/32 [64]	14 [6]
2,3,4 [51,76,102]	7 [178]		1-23/32 [44]	2-7/8 [73]	2-7/8 [73]	15 [7]
3,4 [76,102]	8 [203]	2-1/8 [54]	1-3/4 [44]			17 [8]
6 [152]		1-5/32 [29]	1-3/4 [44]			19 [9]

ENGINEERING SPECIFICATION: ZURN ZN415D-PC
Floor and shower drain, Dura-Coated cast iron body with bottom outlet, combination invertible membrane clamp, adjustable collar with seepage slots and "TYPE D" polished, hinged solid, nickel bronze, light-duty strainer and galvanized steel construction protective cover.

OPTIONS (Check/specify appropriate options)

PIPE SIZE

- 2,3,4 [51,76,102]
- 2 [51]
- 3 [76]
- 4 [102]
- 6 [152]
- 2,3,4 [51,76,102]
- 2,3,4 [51,76,102]

OUTLET (Specify size/type)

- _____ IC Inside Caulk
- _____ IP Threaded
- _____ IP Threaded
- _____ IP Threaded
- _____ IP Threaded
- _____ NH No-Hub
- _____ NL Neo-Loc

'E' BODY HT. DIM.

- 4-3/16 [106]
- 2-7/16 [62]
- 2-3/4 [70]
- 2-13/16 [71]
- 2-7/8 [73]
- 3-13/16 [97]
- 3-7/8 [98]

PREFIXES

- _____ ZB D.C.C.I. Body with Polished Bronze Top
- _____ ZN D.C.C.I. Body with Polished Nickel Bronze Top*

SUFFIXES

- _____ -AR Acid Resistant Epoxy Coated Cast Iron
- _____ -G Galvanized Cast Iron
- _____ -P Trap Primer Connection (Specify 1/2 [13] or 3/4 [19])
- _____ -SA Stabilizer Assembly (See Z1035)
- _____ -SQ Stabilizer Q-Deck (See Z1035-Q)
- _____ -SR Stabilizer Ring (See Z400-U)
- _____ -TC Neo-Loc Test Cap Gasket
- _____ -U (2,3,4 [51,76,102] NL Bottom Outlet Only) 1-3 [25-76] High Extension Adapter
- _____ -V Backwater Valve
- _____ -VP Vandal Proof Secured Top
- _____ -Y Sediment Bucket
- _____ -90 90° Threaded Side Outlet Body

* Regularly furnished unless otherwise specified.