



Z1172-124

LARGE CAPACITY GREASE INTERCEPTOR WITH INSULATED DOUBLE WALL

SPECIFICATION SHEET

TAG _____

Dimensional Data (inches and [mm]) are Subject to Manufacturing Tolerances and Change Without Notice

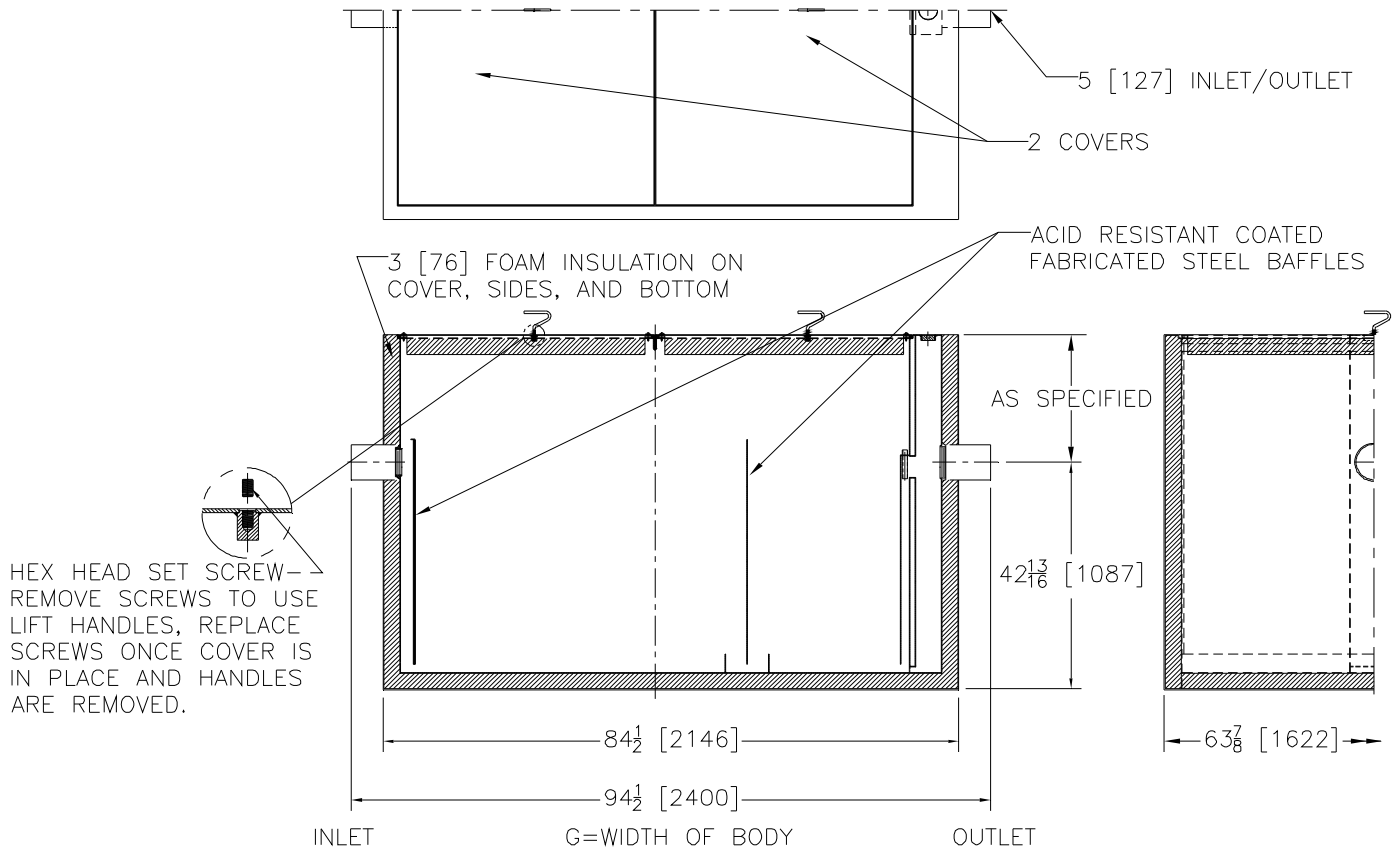

ENGINEERING SPECIFICATION: ZURN Z1172-124

Size 1500 large capacity Acid Resistant Coated interior and exterior fabricated steel grease interceptor rated at 300 GPM 600 Lbs. [2271 lit.] grease capacity, and 665 gal. [2517 lit.] water capacity with fabricated steel extension section, with internal air relief by-pass, bronze cleanout plug and double wall trap seal with removable pressure equalizing/flow diffusing baffle, 2 heavy-duty traffic rated covers rated at 10,000 lbs. [4536 kg.] safe live load. Gasketed non-skid secured cover with removable lift handles, complete with flow control fitting. Acid Resistant Coated interior and exterior fabricated steel insulated double wall unit for recessed installation. Material conforms to AISI 1008 or 1010 and ASTM A36-75. Size 1500 unit UPC classified approval to International Association of Plumbing and Mechanical Officials (IAPMO) Standard PS 80 where applicable. Regularly furnished with inlet and outlet in high position. Uniform insulation thickness of 3 [76]. See Z1172 specification sheet for interceptor details.

OPTIONS (Check/specify appropriate options)

PREFIXES

- ___ Z Acid Resistant Coated Fabricated Steel*
- ___ ZS All Type 304 Fabricated Stainless Steel

SUFFIXES

- ___ -K Anchor flange 1-3/4 [44] down from top and 2 [51] wide.
- ___ -KC Anchor flange 1-3/4 [44] down from top and 2 [51] wide with clamp collar.
- ___ -L Angle type (Z1108-L) flow control device.

*REGULARLY FURNISHED UNLESS OTHERWISE SPECIFIED

REV. A	DATE: 04/22/08	C.N. NO. 98389
DWG. NO. P-15109		PRODUCT NO. Z1172-124