



# Z1750-P

## 12 X 12 [305 x 305] SANI-FLOR RECEPTOR WITH 1/2 [13] TRAP PRIMER CONNECTION 6 [152] SUMP DEPTH

SPECIFICATION SHEET

TAG \_\_\_\_\_

Dimensional Data (inches and [ mm ]) are Subject to Manufacturing Tolerances and Change Without Notice

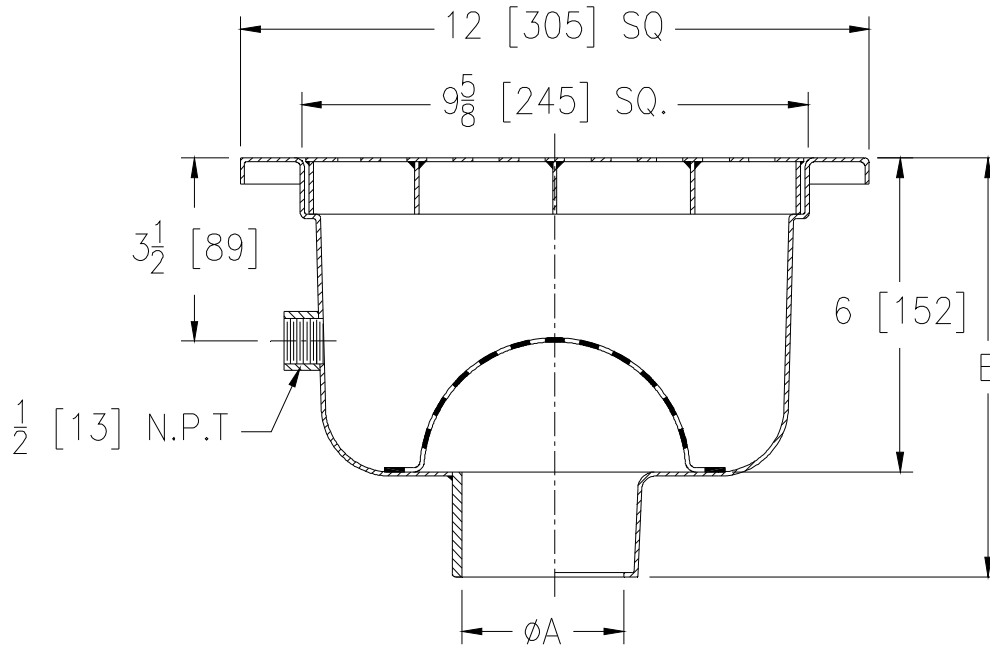

A- Pipe Size In.	Approx. Wt. Lbs. [kg]	Grate Open Area Sq. In. [cm <sup>2</sup> ]
2-3-4 [51-76-102]	15 [7]	23 [148]
6 [152]	17 [8]	

### ENGINEERING SPECIFICATION: ZURN Z1750-P

12 x 12 x 6 [305 x 305 x 152] deep, 16 gage, All Type 304 (CF8) Stainless Steel light-duty Sani-Flor receptor, non-tilt loose set full grate with 1/2 [13] square openings, 1/2 [13] trap primer connection, and anti-splash interior dome strainer.

### OPTIONS (Check/specify appropriate options)

#### PIPE SIZE

2 thru 4 [51 thru 102]  
2 [51]  
3 [76]  
4 [102]  
2 thru 4, 6 [51 thru 102, 152]  
2 thru 4 [51 thru 102]

#### (Specify size/type) OUTLET

\_\_\_ IC Inside Caulk  
\_\_\_ IP Threaded  
\_\_\_ IP Threaded  
\_\_\_ IP Threaded  
\_\_\_ NH No-Hub  
\_\_\_ NL Neo-Loc

#### 'E' BODY HT. DIM.

8 9/16 [214]  
7 5/16 [186]  
7 9/16 [198]  
8 1/16 [205]  
8 1/16 [205]  
7 13/16 [198]

### PREFIXES

\_\_\_ Z Type 304 (CF8) Stainless Steel Body\*  
\_\_\_ ZM Type 316 (CF8M) Stainless Steel

### SUFFIXES

___ -DX	Dex-o-tex Flange	___ -3	3/4 Grate
___ -HD	Extra Heavy Duty Grate	___ -4	Full Grate w/ 3 [76] Square Opening
___ -HP	Heel-Proof Grate	___ -5	Grate w/ 4 [102] Dia. x 3 3/4 [95] High Type 304 Stainless Steel Funnel
___ -K	Anchor Flange w/ Seepage Holes	___ -8	Grate w/ 8 3/8 x 3 5/8 x 3 3/4 [213 x 92 x 95] High Type 304 Stainless Steel Oval Funnel
___ -KC	Anchor Flange w/ Seepage Holes and Clamp Collar	___ -15	Solid Cover
___ -LSH	(Less) Seepage Holes	___ -16	1/2 Solid Cover
___ -SG	Solid Gasketed Cover	___ -17	3/4 Solid Cover
___ -TC	Neo-Loc Test Cap Gasket (2 - 4 [51 - 102] NL Bottom Outlet Only)	___ -18	Solid Cover w/ 3 [76] Square Center Opening
___ -VP	Vandal-Proof Secured Top	___ -19	Full Hinged Grate
___ -Y	Sediment Bucket	___ -20	Full Hinged Solid Cover
___ -YS	Suspended Sediment Bucket		
___ -1	(Less) Grate		
___ -2	1/2 Grate		

\*REGULARLY FURNISHED UNLESS OTHERWISE SPECIFIED

REV. DATE: 8/10/09 C.N. NO. 110040

DWG. NO. 84286 PRODUCT NO. Z1750-P

ZURN INDUSTRIES, LLC ♦ SPECIFICATION DRAINAGE OPERATION ♦ 1801 Pittsburgh Ave. ♦ Erie, PA 16514

Phone: 814/455-0921 ♦ Fax: 814/454-7929 ♦ World Wide Web: www.zurn.com

In Canada: ZURN INDUSTRIES LIMITED ♦ 3544 Nashua Drive ♦ Mississauga, Ontario L4V1L2 ♦ Phone: 905/405-8272 Fax: 905/405-1292