

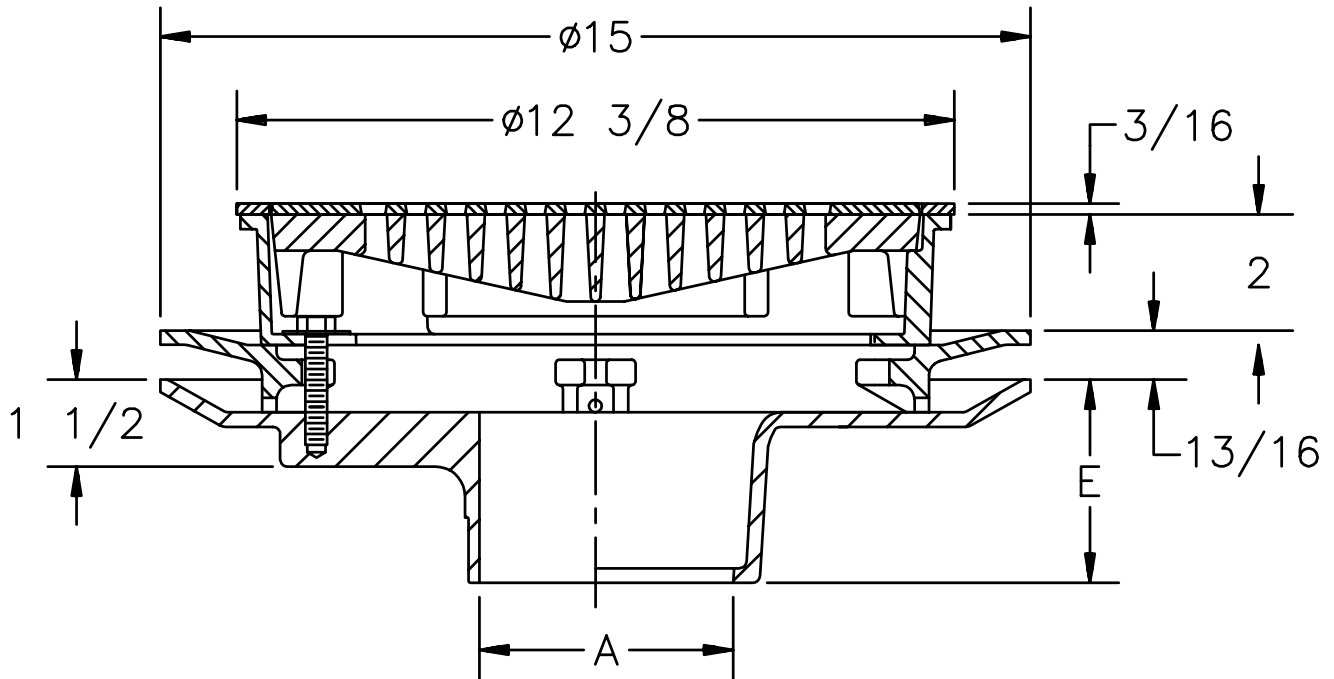

Z-509-78 12" HEAVY DUTY DRAIN

TAG _____

Dimensional Data (inches and [mm]) are Subject to Manufacturing Tolerances and Change Without Notice



A- Pipe Size In.	Approx. Wt. Lbs.	Grate Open Area Sq. In.
3-4-6	38	20

ENGINEERING SPECIFICATION: ZURN ZN-509-78 12" Diameter top drain. Dura-Coated cast iron body with bottom outlet, seepage pan and combination membrane flashing clamp, extension with weep holes and nickel bronze frame and heel proof grate.

OPTIONS (Check/specify appropriate options)

OUTLET (Specify type)

- _____ **IC** Inside Caulk
- _____ **IG** Inside Caulk w/Sealtrol Gskt.
- _____ **IP** Threaded
- _____ **NH** No-Hub
- _____ **NL** Neo-Loc

PIPE SIZE (Specify size)

- _____ 3", 4", 6"
- _____ 3", 4", 6"
- _____ 3", 4", 6"
- _____ 3", 4", 6"
- _____ 3", 4"

'E' BODY HT. DIMENSION

- 3-1/2"
- 3-1/2"
- 3-1/2"
- 3-1/2"
- 2-5/8"

PREFIXES

- _____ **ZB-** D.C.C.I. Body with Polished Bronze Grate
- _____ **ZN-** D.C.C.I. Body with Polished Nickel Bronze Grate*

SUFFIXES

- _____ **-G** Galvanized Cast Iron
- _____ **-S** Secondary Strainer
- _____ **-T** Square Top
- _____ **-V** Backwater Valve (See Z-1099)
- _____ **-VP** Vandal Proof Secured Top
- _____ **-Y** Sediment Bucket
- _____ **-90** 90° Threaded Side Outlet Body

REV.	DATE: 11/13/92	C.N. NO. 68704
DWG. NO. P-13769 PRODUCT NO. Z-509-78		

*REGULARLY FURNISHED UNLESS OTHERWISE SPECIFIED