



Z121-115

SMALL AREA PLANTING DRAIN WITH LOWER ISOLATION DECK DRAIN BODY

SPECIFICATION SHEET

TAG _____

Dimensional Data (inches and [mm]) are Subject to Manufacturing Tolerances and Change Without Notice

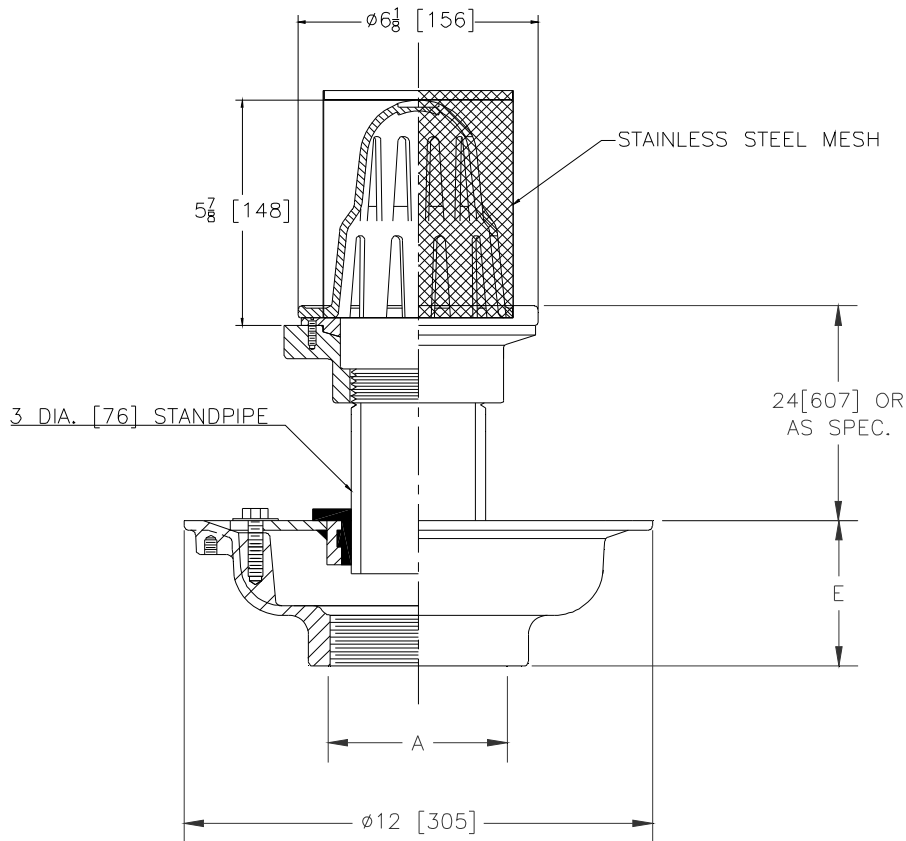

A- Pipe Size In.	Approx. Wt. Lbs. [kg]	Dome Open Area Sq. In. [cm ²]
2-3-4-5-6 [51-76-102-127-152]	35 [16]	20 [129]

ENGINEERING SPECIFICATION: ZURN Z121-115
 Small Area Planting Drain with lower Isolation Deck Drain Body. Dura-Coated cast iron upper and lower bodies with membrane flashing clamp with 6 [152] Diameter by 2 [51] High Cornice Drain with plain bronze high dome, mesh screen, membrane flashing clamp, clamp collar, neoprene flex gasket and isolation nipple.

OPTIONS (Check/specify appropriate options)

PIPE SIZE

- 2 thru 6 [51 thru 152]
- 2,3,4,6 [51,76,102,152]
- 2 thru 6 [51 thru 152]
- 2 thru 6 [51 thru 152]
- 2-3-4 [51-76-102]

(Specify size/type) **OUTLET**

- _____ IC Inside Caulk
- _____ IP Threaded
- _____ IP Threaded
- _____ NH No-Hub
- _____ NL Neo -Loc

E BODY HT. DIM.

- 5-1/4 [133]
- 3 3/4 [95]
- 3-3/4 [95]
- 5-1/4 [133]
- 4-5/8 [117]

PREFIXES

_____ ZRB- D.C.C.I. Body with Plain Bronze Dome

SUFFIXES

- _____ -AR Acid Resistant Epoxy Coated Finish
- _____ -C Underdeck Clamp
- _____ -G Galvanized Cast Iron
- _____ -R Roof Sump Receiver
- _____ -VP Vandal Proof Secured Top

REV.	DATE: 11/14/12	C.N. NO. 128477
DWG. NO. 310936		PRODUCT NO. Z121-115

*REGULARLY FURNISHED UNLESS OTHERWISE SPECIFIED