



# Z1170-124

## GREASE INTERCEPTOR INSPECTION TANK

SPECIFICATION SHEET

TAG \_\_\_\_\_

Dimensional Data (inches and [ mm ]) are Subject to Manufacturing Tolerances and Change Without Notice

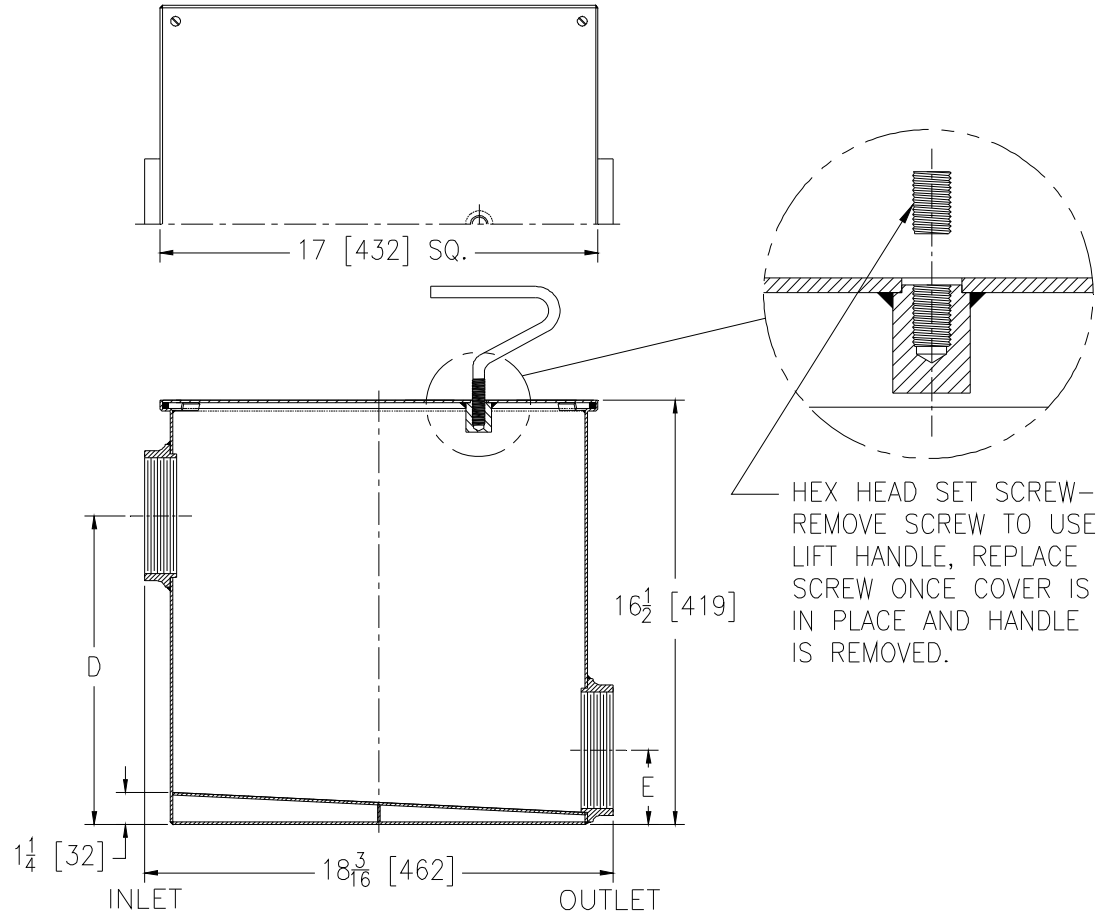

Inlet/ Outlet Size**	Approx. Wt. Lbs. [kg]	Dimensions In Inches [mm]	
		D	E
2 [51]	93 [42]	12 [305]	1 9/16 [40]
3 [76]	93 [42]	12 [305]	2 11/32 [60]
4 [102]	93 [42]	12 [305]	2 7/8 [73]
6 [152]	93 [42]	10 3/4 [273]	4 3/4 [100]

**ENGINEERING SPECIFICATION: ZURNZ1170-124**  
 Acid Resistant Coated interior and exterior fabricated steel grease interceptor inspection tank, non-skid secured cover, and sloped bottom. Regularly furnished with high inlet and low outlet.

**OPTIONS** (Check/specify appropriate options)

**PREFIXES**

\_\_\_ Z Acid Resistant Coated Fabricated Steel\*

**SUFFIXES**

\_\_\_ -E Acid Resistant Coated interior and exterior fabricated steel extension section (Specify 'C' dimension required for recessed installation).

\_\_\_ -HD Heavy Duty traffic cover rated at 10,000 lbs. [4536 kg.] maximum safe load. A 3 [76] minimum extension height is required when Heavy Duty cover (-HD) option is specified.

\*\* REGULARLY FURNISHED WITH 4 [102] INLET/OUTLET UNLESS OTHERWISE SPECIFIED

REV. C	DATE: 10/1/09	C.N. NO. 110272
DWG. NO. P-15513	PRODUCT NO. Z1170-124	

\*REGULARLY FURNISHED UNLESS OTHERWISE SPECIFIED