



Z530-82

9 [229] WIDE FLANGE DECK DRAIN WITH
2 [51] TALL WATER DAM

SPECIFICATION SHEET

TAG _____

Dimensional Data (inches and [mm]) are Subject to Manufacturing Tolerances and Change Without Notice

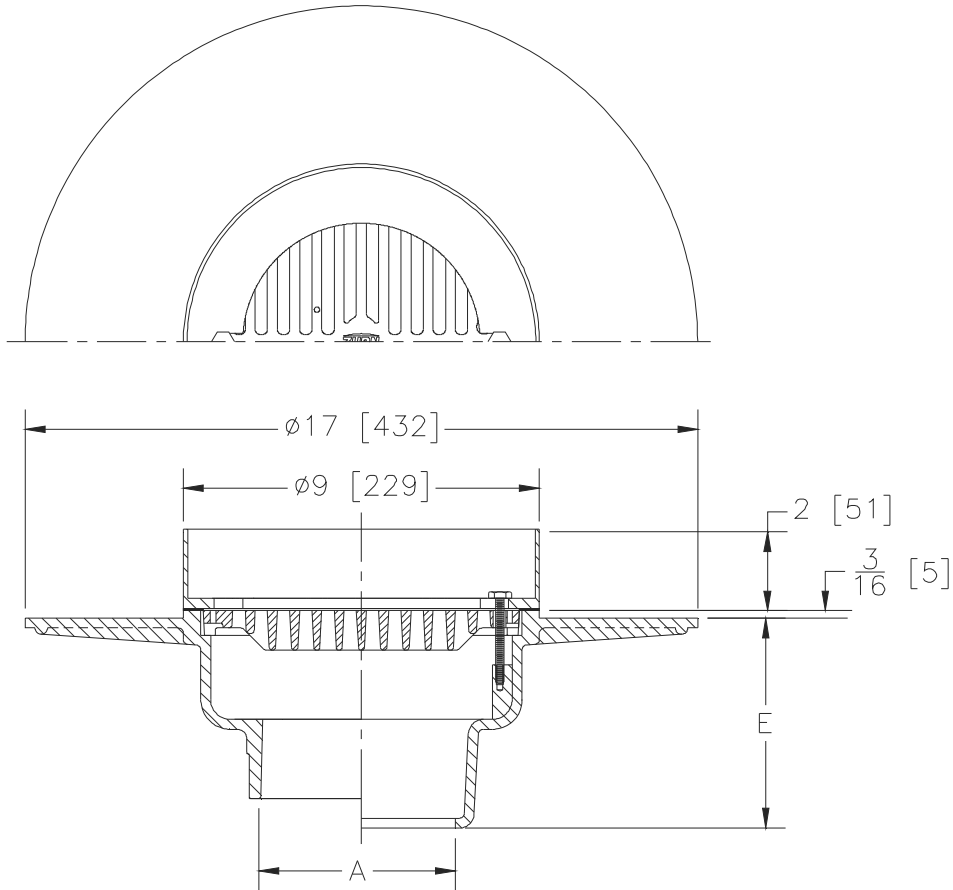

A- Pipe Size In. [mm]	Approx. Wt. Lbs. [kg]	Dome Open Area Sq. In. [cm ²]
2,3,4 [51,76,102]	49 [22]	43 [116]

ENGINEERING SPECIFICATION: ZURNZ530-81

9" [229mm] Diameter wide flange deck drain for latex decks, Dura-Coated cast iron body with latex troweling flange. Complete with 2" [51mm] tall water dam and cast iron grate.

OPTIONS (Check/specify appropriate options)

PIPE SIZE

2,3,4 [51,76,102]
2,3,4 [51,76,102]
2,3,4 [51,76,102]
2,3,4 [51,76,102]

(Specify size/type) OUTLET

___ IC Inside Caulk
___ IG Inside Gasket
___ IP Threaded
___ NL Neo-Loc

'E' BODY HT. DIM.

5-1/2 [140]
5-1/2 [140]
4 [102]
4-3/4 [121]

PREFIXES

___ Z D.C.C.I. Body and Coated Carbon Steel Water Dam with Cast Iron Dome
___ ZS D.C.C.I. Body and Stainless Steel Water Dam with Cast Iron Dome

SUFFIXES

___ -AR Acid Resisting Epoxy Coated Cast Iron
___ -C Underdeck Clamp
___ -G Galvanized Cast Iron
___ -TC Neo-Loc Test Cap Gasket
(2,3,4 [51,76,102] NL Bottom Outlet Only)
___ -XJ Expansion Joint (See Z190)

* Regularly furnished unless otherwise specified.

Zurn Industries, LLC | Specification Drainage Operation

1801 Pittsburgh Avenue, Erie, PA U.S.A. 16502 · Ph. 855-663-9876, Fax 814-454-7929

In Canada | Zurn Industries Limited

3544 Nashua Drive, Mississauga, Ontario L4V 1L2 · Ph. 905-405-8272, Fax 905-405-1292

www.zurn.com

Rev. -

Date: 03/17/17

C.N. No. 136454

Prod. | Dwg. No. Z530-82