



Z107-100

20 [508] DIA. MAIN ROOF DRAIN W/ 10 [254] SQ. PROM-DECK DRAIN

SPECIFICATION SHEET

TAG _____

Dimensional Data (inches and [mm]) are Subject to Manufacturing Tolerances and Change Without Notice

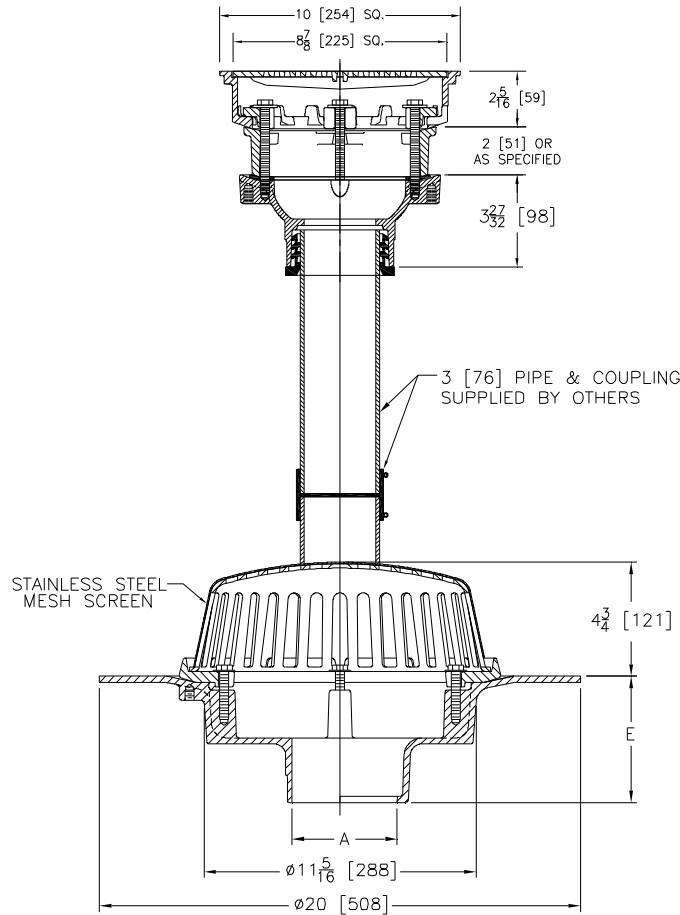

A Pipe Size In.	Approx. Wt. Lbs. [kg]	Grate Open Area Sq. In. [cm ²]
3, 4 [76, 102]	59 [27]	21 [136]
6, 8 [152, 203]		

ENGINEERING SPECIFICATION: ZURN Z107-100

20 [508] Diameter wide deck flange roof drain. Dura-Coated cast iron with combination membrane flashing clamp/gravel guard and low silhouette Poly-Dome with stainless steel mesh screen. Upper body consists of 10 [254] Prom-Deck drain, Dura-Coated cast iron body with rotatable square promenade frame, frame clamps, light-duty heel-proof grate and static extension.

OPTIONS (Check/specify appropriate options)

PIPE SIZE

- 3, 4, 6 [76, 102, 152]
- 3, 4 [76, 102]
- 3, 4, 6, 8 [76, 102, 152, 203]

(Specify size/type) **OUTLET**

- ___ IC Inside Caulk
- ___ IP Threaded
- ___ NH No-Hub

E BODY HT. DIM.

- 5 1/4 [133]
- 5 1/4 [133]
- 5 1/4 [133]

PREFIXES

- ___ Z D.C.C.I. Body with Top*
- ___ ZB D.C.C.I. Body with Polished Bronze Top
- ___ ZN D.C.C.I. Body with Polished Nickel Bronze Top

SUFFIXES

- ___ -AR Acid Resistant Epoxy Coated
- ___ -C Underdeck Clamp
- ___ -VP Vandal-Proof Secured Top

*REGULARLY FURNISHED UNLESS OTHERWISE SPECIFIED

REV.	DATE: 10/01/08	C.N. NO. 99161	
DWG. NO. P-15607	PRODUCT NO. Z107-100		

ZURN INDUSTRIES, LLC ♦ SPECIFICATION DRAINAGE OPERATION ♦ 1801 Pittsburgh Ave. ♦ Erie, PA 16514

Phone: 814455-0921 ♦ Fax: 814454-7929 ♦ World Wide Web: www.zurn.com

In Canada: ZURN INDUSTRIES LIMITED ♦ 3544 Nashua Drive ♦ Mississauga, Ontario L4V1L2 ♦ Phone: 905405-8272 Fax: 905405-1292