



# Z1108-80

SPECIFICATION SHEET

## GREASE INTERCEPTOR

### FLOW CONTROL ACCESS BOX FOR RECESSING RECEIVER TAG \_\_\_\_\_

Dimensional Data (inches and [ mm ]) are Subject to Manufacturing Tolerances and Change Without Notice

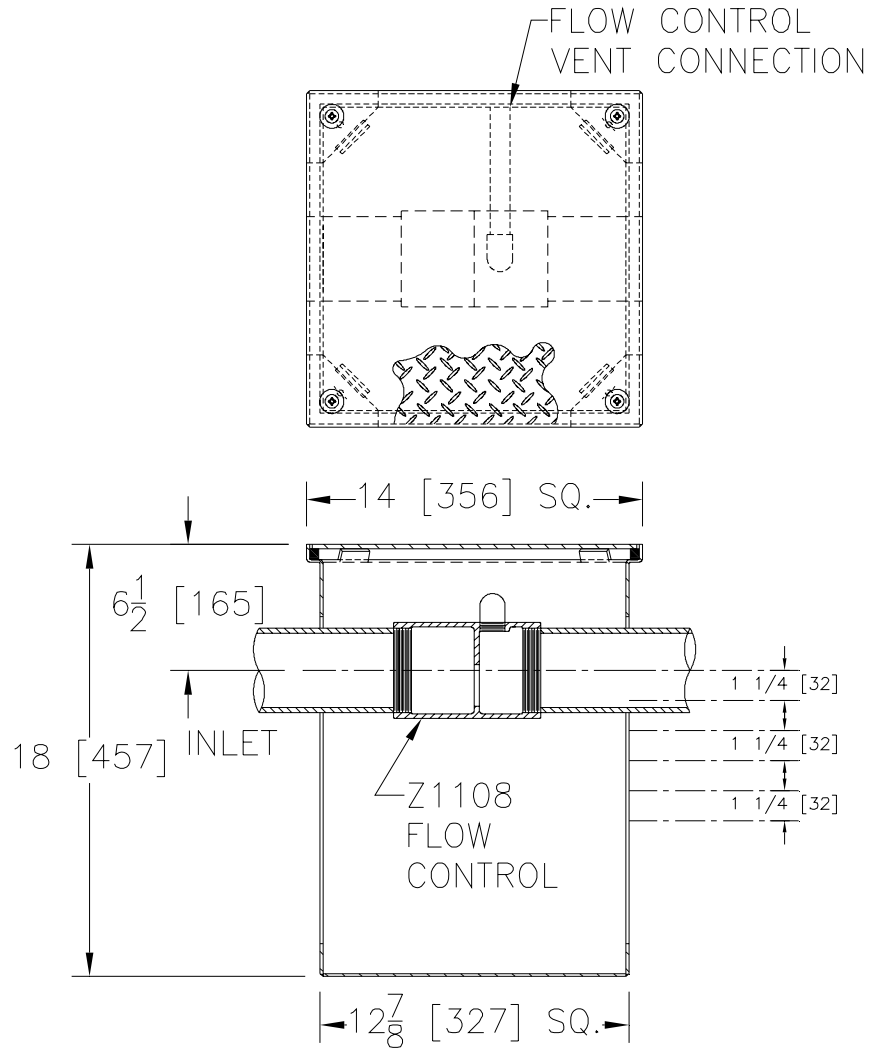

Inlet/ Outlet Size	Approx. Wt. Lbs. [kg]
4[102]	50[23]

**ENGINEERING SPECIFICATION:** ZURN Z1108-80 Acid Resistant Coated interior and exterior fabricated steel access box with slotted openings for use with Z1170-600 grease interceptor recessing receiver, complete with gasketed non-skid secured cover.

#### PREFIXES

\_\_\_ Z Acid Resistant Coated Fabricated Steel\*

#### SUFFIXES

- \_\_\_ -E Acid Resistant Coated Interior and exterior fabricated steel integral extension section. (Specify 'C' Dim. required) for recessed installation.
- \_\_\_ -K Anchor flange 1 3/4 [44] down from top and 2 [51] wide.
- \_\_\_ -KC Anchor flange 1 3/4 [44] down from top and 2 [51] wide with clamp collar.

\*REGULARLY FURNISHED UNLESS OTHERWISE SPECIFIED

REV.	DATE: 4/24/08	C.N. NO. 98396
DWG. NO. P-15542 PRODUCT NO. Z1108-80		

ZURN INDUSTRIES, LLC. ♦ SPECIFICATION DRAINAGE OPERATION ♦ 1801 Pittsburgh Ave. ♦ Erie, PA 16514

Phone: 814/455-0921 ♦ Fax: 814/454-7929 ♦ World Wide Web: www.zurn.com

In Canada: ZURN INDUSTRIES LIMITED ♦ 3544 Nashua Drive ♦ Mississauga, Ontario L4V1L2 ♦ Phone: 905/405-8272 Fax: 905/405-1292