



Z100-227

SPECIFICATION SHEET

15 [381] DIAMETER MAIN ROOF DRAIN WITH SUBSURFACE OVERFLOW, PERFORATED EXTENSION AND FLUSH GRATE TAG _____

Dimensional Data (inches and [mm]) are Subject to Manufacturing Tolerances and Change Without Notice

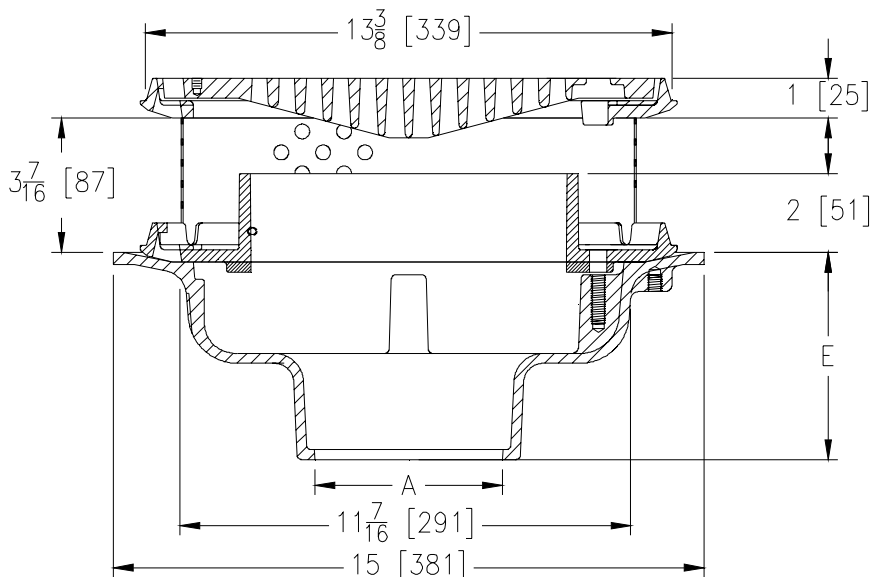

A Pipe Size In.	Approx. Wt. Lbs. [kg]	Dome Open Area Sq. In. [cm ²]
2,3,4 [51,76,102]	31 [14]	32 [206]
5,6 [127,152]	32 [15]	
8 [203]	33 [15]	

ENGINEERING SPECIFICATION: ZURN Z100-227

15 [381] Diameter roof drain. Dura-Coated cast iron body with combination membrane flashing clamp/gravel guard and with 2 [51] internal water dam, perforated extension, combination membrane flashing clamp / gravel guard and flush grate.

OPTIONS (Check/specify appropriate options)

(Specify size/type) **OUTLET**

- _____ IC Inside Caulk
- _____ IP Threaded
- _____ NH No-Hub
- _____ NL Neo-Loc
- _____ NL Neo-Loc

E BODY HT. DIM.

- 5 1/4 [133]
- 3 3/4 [95]
- 5 1/4 [133]
- 4 9/16 [116]
- 5 7/16 [112]

PIPE SIZE

- 2 thru 6,8 [51 thru 152,203]
- 2 thru 6,8 [51 thru 152,203]
- 2 thru 6,8 [51 thru 152,203]
- 2,3,4 [51,76,102]
- 6 [152]

PREFIXES

- _____ Z D.C.C.I. Body and Grate*

SUFFIXES

- _____ -AC Angular Underdeck Clamp
- _____ -AR Acid Resistant Epoxy Coated
- _____ -C Underdeck Clamp
- _____ -DE Deck Extension
- _____ -DP Top-Set® Deck Plate (Replaces both the -C and -R)
- _____ -DR Top-Set® Drain Riser
- _____ -DX Dex-o-tex Flange
- _____ -E Static Extension 1 [25] thru 4 [102] (Specify Ht.)
- _____ -EA Adjustable Extension Assembly
2 1/8 [54] thru 3 1/2 [89]
- _____ -EB Top-Set® Adjustable Extension Assembly
- _____ -G Galvanized Cast Iron
- _____ -R Roof Sump Receiver
- _____ -SC Secondary Clamp Collar
- _____ -TC Neo-Loc Test Cap Gasket
(2 - 4 [51 - 102] NL Bottom Outlet Only)
- _____ -VP Vandal-Proof Secured Top
- _____ -84 Stainless Steel Perforated Gravel Guard
- _____ -90 90° Threaded Side Outlet Body
(2 thru 6 [51 or 152])

REV.	DATE: 9/24/10	C.N. NO. 111752
DWG. NO. 302557		PRODUCT NO. Z100-227

*REGULARLY FURNISHED UNLESS OTHERWISE SPECIFIED

ZURN INDUSTRIES, LLC ♦ SPECIFICATION DRAINAGE OPERATION ♦ 1801 Pittsburgh Ave. ♦ Erie, PA 16514

Phone: 814/455-0921 ♦ Fax: 814/454-7929 ♦ World Wide Web: www.zurn.com

In Canada: ZURN INDUSTRIES LIMITED ♦ 3544 Nashua Drive ♦ Mississauga, Ontario L4V1L2 ♦ Phone: 905/405-8272 Fax: 905/405-1292