



Z100-C-R-W3

15 [381] DIAMETER ROOF DRAIN W/ UNDERDECK CLAMP, ROOF SUMP RECEIVER, AND 3 [76] HIGH WATER DAM

SPECIFICATION SHEET

TAG _____

Dimensional Data (inches and [mm]) are Subject to Manufacturing Tolerances and Change Without Notice

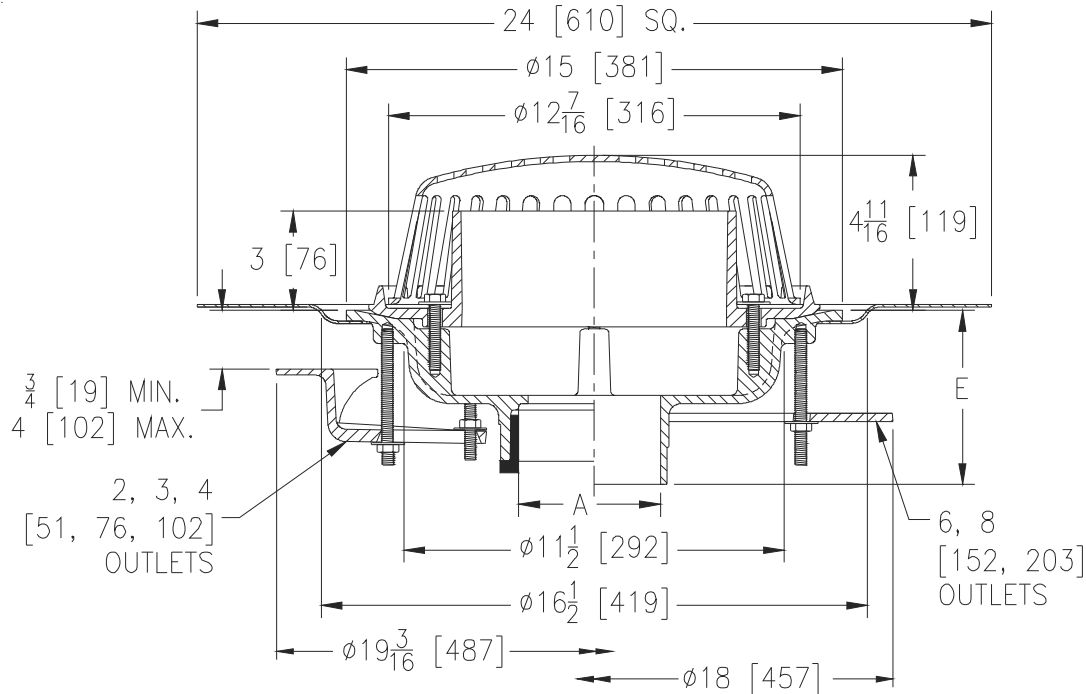

A Pipe Size in [mm]	Approx Wt. lbs [kg]	Dome Open Area in ² [cm ²]
2,3,4 [51,76,102]	42 [19]	103 [665]
6 [152]	45 [20]	
8 [203]	46 [21]	

ENGINEERING SPECIFICATION: ZURN Z100-C-R-W3

15" [381mm] Diameter roof drain. Dura-Coated cast iron body with underdeck clamp, combination membrane flashing clamp/gravel guard, roof sump receiver, 3" [76mm] high internal water dam, and low silhouette Poly-Dome.

OPTIONS (Check/specify appropriate options)

PIPE SIZE

3,4,6 [76,102,152]
 2,3,4,6,8 [51,76,102,152,203]
 2,3,4,6,8 [51,76,102,152,203]
 2,3,4 [51,76,102]
 6 [152]

(Specify size/type) OUTLET

_____ IC Inside Caulk
 _____ IP Threaded
 _____ NH No-Hub
 _____ NL Neo-Loc
 _____ NL Neo-Loc

E BODY HT. DIM.

5-1/4 [133]
 3-3/4 [95]
 5-1/4 [133]
 4-5/8 [117]
 5-7/16 [138]

PREFIXES

_____ Z D.C.C.I. Body with Poly-Dome*
 _____ ZA D.C.C.I. Body with High Aluminum Dome
 _____ ZC D.C.C.I. Body with Cast Iron Dome
 _____ ZRB D.C.C.I. Body with Plain Bronze Dome

SUFFIXES

_____ -AR Acid Resistant Epoxy Coated
 _____ -E Static Extension 1" [25] thru 4" [102] (Specify Ht.)
 _____ -EA Adjustable Extension Assembly
 2-1/8 [54] thru 3-1/2 [89]
 _____ -G Galvanized Cast Iron
 _____ -HD 6-3/4 [171] High Aluminum Dome
 (148 sq. in. [955 cm²] open area)
 _____ -SC Secondary Clamping Collar
 _____ -SS Stainless Mesh Screen Over Dome
 _____ -ST Dome w/ Solid Top (ZA and ZC Only)
 _____ -TC Neo-Loc Test Cap Gasket
 (2,3,4 [51,76,102] NL Bottom Outlet Only)
 _____ -VP Vandal Proof Secured Top
 _____ -84 Stainless Steel Perforated Gravel Guard
 _____ -90 90° Threaded Side Outlet Body

* Regularly furnished unless otherwise specified.