



Z541-130

SPECIFICATION SHEET

Ø12 [305] HEAVY-DUTY DRAIN W/ STAINLESS STEEL HEEL-PROOF PERFORATED GRATE

TAG _____

Dimensional Data (inches and [mm]) are Subject to Manufacturing Tolerances and Change Without Notice

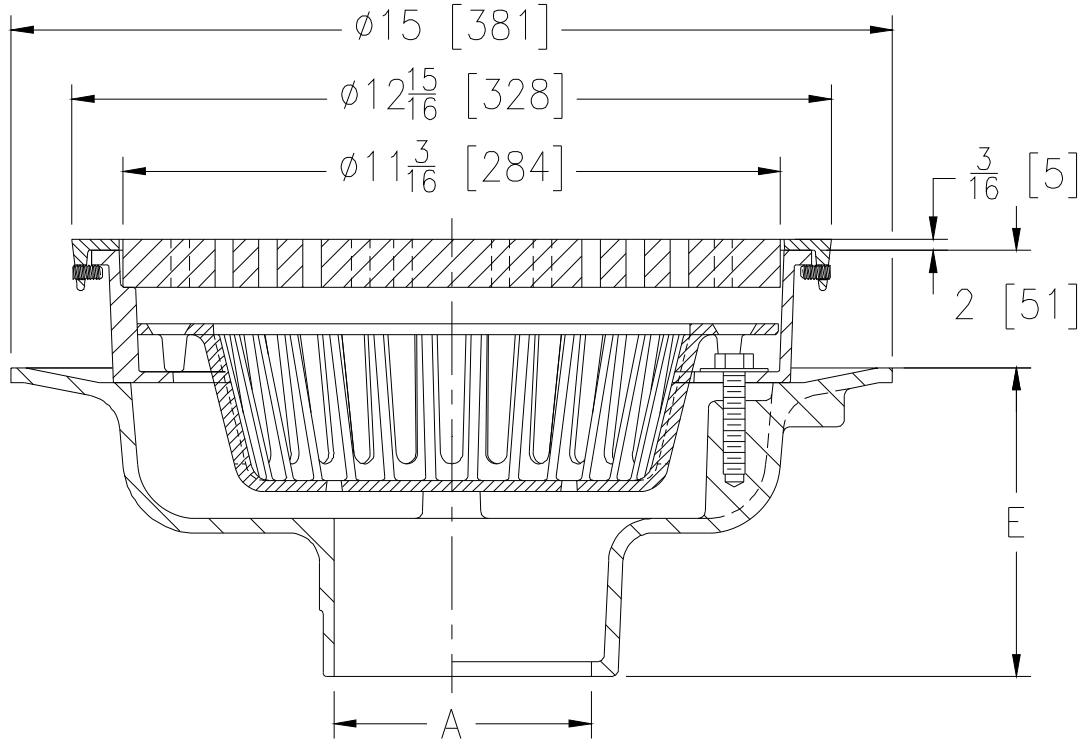

A- Pipe Size In.	Approx. Wt. Lbs. [kg]	Grate Open Area Sq. In. [cm ²]
2-3-4 [51-76-102]	51 [19]	13 [84]
5 [127]	52 [19]	

ENGINEERING SPECIFICATION: ZURN Z541-130

12 [305] Diameter top drain. Dura-Coated cast iron body with bottom outlet, seepage pan and combination membrane flashing clamp and frame for stainless steel perforated heel-proof grate with suspended polypropylene sediment bucket.

OPTIONS (Check/specify appropriate options)

PIPE SIZE

(Specify size/type) **OUTLET**

'E' BODY HT. DIM.

2 thru 5 [51 thru 127]	_____ IC	Inside Caulk	5-1/4 [133]
2 thru 4 [51 thru 102]	_____ IG	Inside Gasket	5-1/4 [133]
2 thru 5 [51 thru 127]	_____ IP	Threaded	3-3/4 [95]
2 thru 5 [51 thru 127]	_____ NH	No-Hub	5-1/4 [133]
2 thru 4 [51 thru 102]	_____ NL	Neo-Loc	4-5/8 [117]

PREFIXES

_____ Z D.C.C.I. Body and Stainless Steel Top*

SUFFIXES

_____ -AR Acid Resisting Epoxy Coated Cast Iron
 _____ -DX Dex-o-tex Flange
 _____ -LY (Less) Sediment Bucket
 _____ -P Trap Primer Connection
 _____ -S Secondary Strainer
 _____ -SA Stabilizer Assembly (See Z1036)
 _____ -SS Stainless Mesh Liner for Bucket

_____ -TC Neo-Loc Test Cap Gasket
 (2 [51] - 4 [102] NL Bottom Outlet Only)
 _____ -V Backwater Valve (See Z1099)
 _____ -YC Cast Iron Sediment Bucket
 _____ -90 90° Threaded Side Outlet Body
 (2 thru 6 [51 thru 152])

*REGULARLY FURNISHED UNLESS OTHERWISE SPECIFIED

REV. DATE: 05/25/12 C.N. NO. 124422

DWG. NO. 309839

PRODUCT NO. Z541-130