

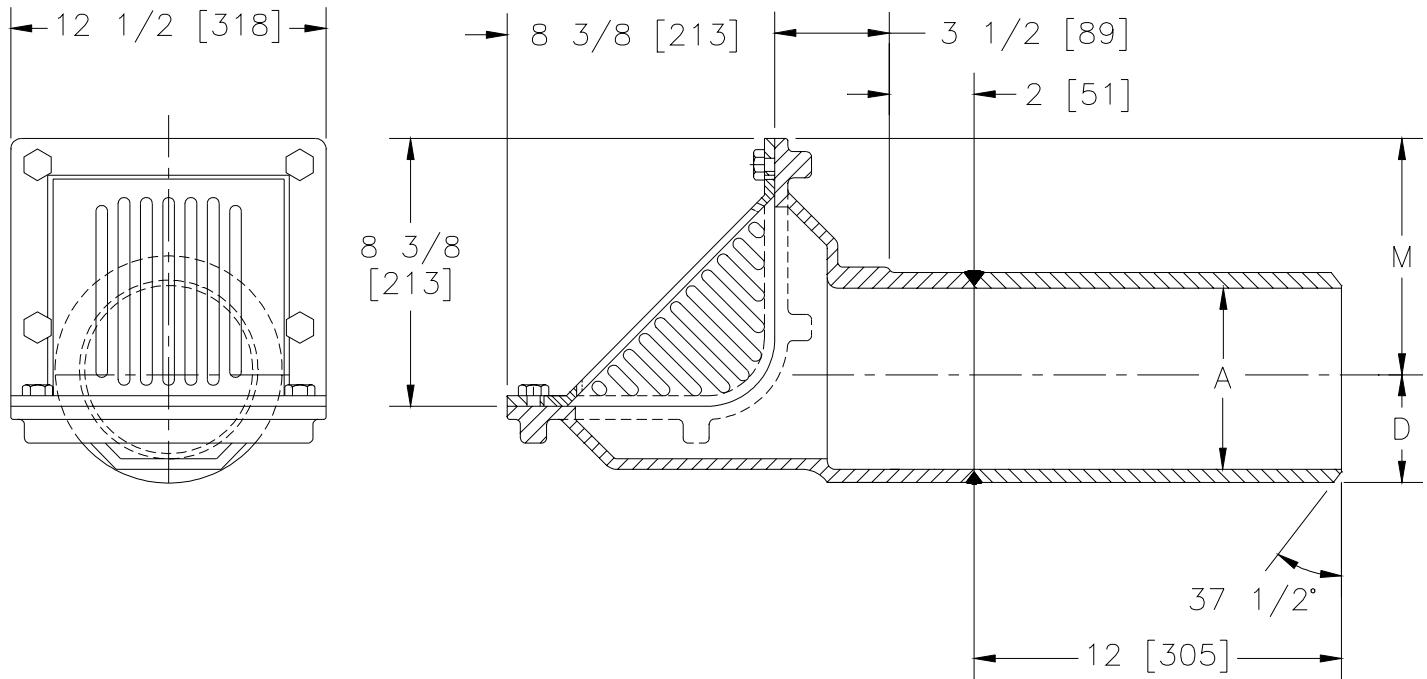

Z-1717-75 SCUPPER DRAIN

TAG _____

Dimensional Data (inches and [mm]) are Subject to Manufacturing Tolerances and Change Without Notice



Dimensions in Inches			Approx. Wt. Lbs. [kg]	Grate Open Area Sq. In. [cm ²]
A- Pipe Size	D	M		
6 [152]	3 5/16 [79]	7-7/8 [200]	32 [15]	57 [368]

ENGINEERING SPECIFICATION: ZURN Z-1717-75
Scupper drain with Type 304 (CF8) stainless steel body with extra 12" nipple and cast aluminum oblique grate and clamp collar.

OPTIONS (Check/specify appropriate options)

PIPE SIZE (Specify size/type) **OUTLET**
6 [152] _____ BW Butt-weld
(Specify Schedule 10,40 or 80)

PREFIXES

- _____ Z- Type 304 (CF8) Stainless Steel Body*
- _____ ZC- Type A-27 Carbon Steel Body (P.O.A.)
- _____ ZM- Type 316 (CF8M) Stainless Steel Body

*REGULARLY FURNISHED UNLESS OTHERWISE SPECIFIED

REV.	DATE: 9/7/00	C.N. NO. 85858
DWG. NO. P-14795 PRODUCT NO. Z-1717-75		