



# Z1187-SI-77 SAND/SEDIMENT INTERCEPTOR

SPECIFICATION SHEET

TAG \_\_\_\_\_

Dimensional Data (inches and [ mm ]) are Subject to Manufacturing Tolerances and Change Without Notice

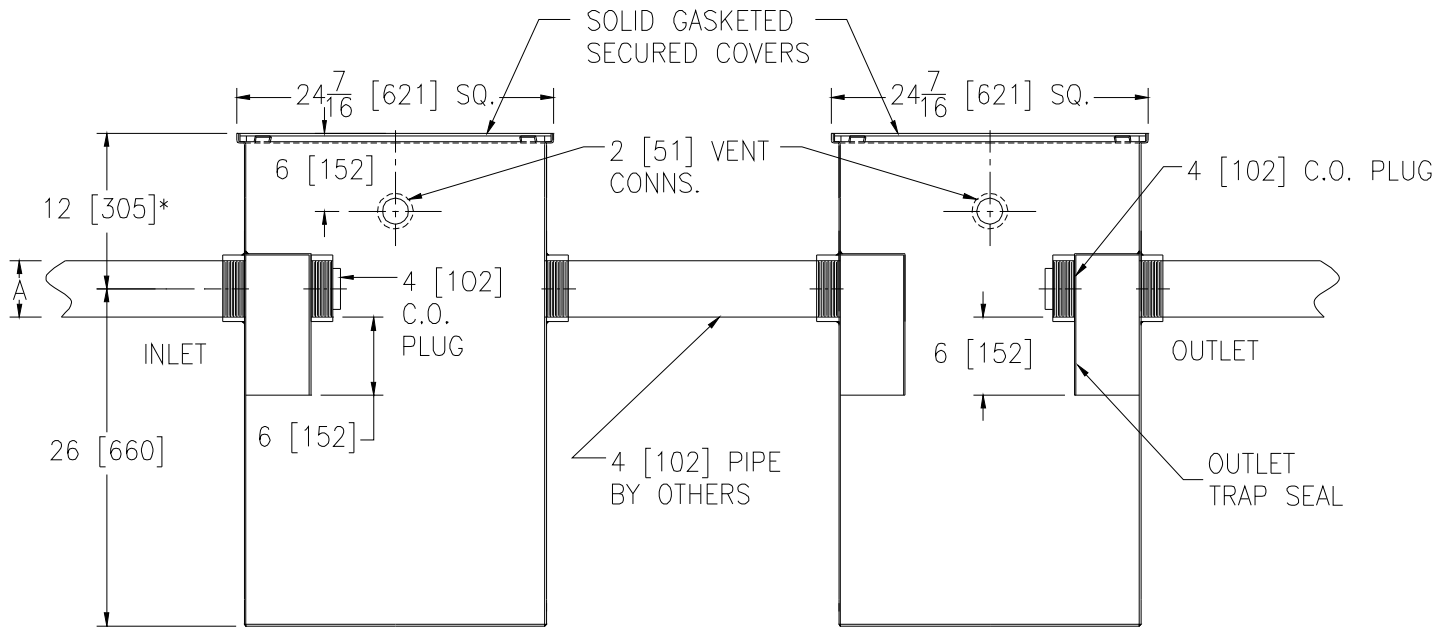

\*12[305] REGULARLY FURNISHED -  
SPECIFY DIMENSION IF HIGHER  
OR LOWER IS REQUIRED

Pipe Size	Capacity Gal. [L] (Static)
4 [102]	110 [416]

**ENGINEERING SPECIFICATION:** ZURN Z1187-SI-77 Acid Resistant Coated interior and exterior fabricated steel two-unit sand/sediment separator with threaded inlet and outlet, solid gasketed secured covers, 2 [51] vent connections, 4 [102] cleanouts on inlet and outlet baffles, complete with 6 [152] deep water seals.

**OPTIONS** (Check/specify appropriate options)

**PREFIXES**

\_\_\_ Z Acid Resistant Coated Fabricated Steel\*

**SUFFIXES**

- \_\_\_ -E Acid Resistant Coated interior and exterior fabricated steel extension section (specify overall height required).
- \_\_\_ -HD Heavy duty traffic cover rated at 10,000 lbs. maximum safe live load.

REV.	DATE: 2/20/04	C.N. NO. 91957
DWG. NO. P-15035 PRODUCT NO. Z1187-SI-77		

\*REGULARLY FURNISHED UNLESS OTHERWISE SPECIFIED