

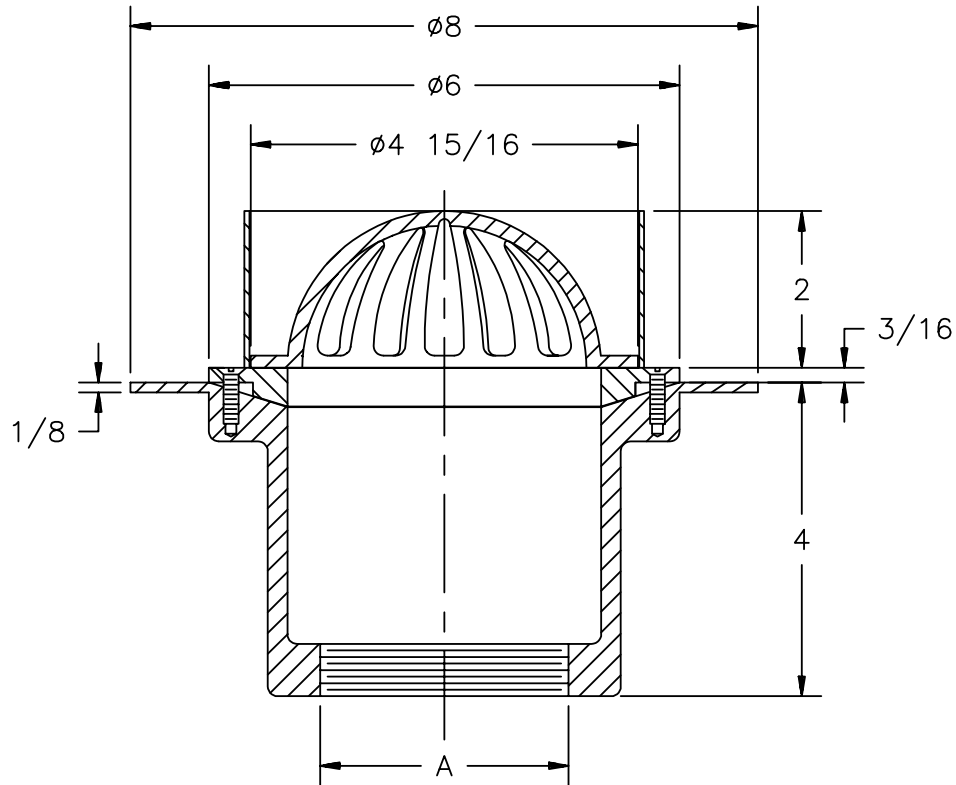

# Z-181-77 6" DIAMETER CORNICE DRAIN BOTTOM OUTLET

TAG \_\_\_\_\_

Dimensions Subject to Manufacturing Tolerances



| A- Pipe Size In. | Approx. Wt. Lbs. | Dome Open Area Sq. In. |
|------------------|------------------|------------------------|
| 3                | 8                | 12                     |
| 4                | 9                |                        |

**ENGINEERING SPECIFICATION:** ZURN ZRB-181-77 6" Diameter by 4" High Cornice drain with 8" diameter flange, Dura-Coated cast iron body, plain bronze dome, 2" high water dam and membrane flashing clamp.

**OPTIONS** (Check/specify appropriate options)

**OUTLET** (Specify type)

- \_\_\_\_\_ IP Threaded
- \_\_\_\_\_ NH No-Hub

**PIPE SIZE** (Specify size)

- \_\_\_\_\_ 3", 4"
- \_\_\_\_\_ (IP w/Z-1040)

**PREFIXES**

- \_\_\_\_\_ ZRB- D.C.C.I. Body with Plain Bronze Dome\*
- \_\_\_\_\_ ZB- D.C.C.I. Body with Polished Bronze Dome
- \_\_\_\_\_ ZN- D.C.C.I. Body with Polished Nickel Bronze Dome

**SUFFIXES**

- \_\_\_\_\_ -BS Bronze Mesh Screen Over Dome
- \_\_\_\_\_ -FS Flat Strainer (ZB or ZN)
- \_\_\_\_\_ -G Galvanized Cast Iron
- \_\_\_\_\_ -HD 5-3/4" High Dome
- \_\_\_\_\_ -VP Vandal Proof Secured Top
- \_\_\_\_\_ -8 With 8" High Body

|                                       |               |                |
|---------------------------------------|---------------|----------------|
| REV.                                  | DATE: 6/29/93 | C.N. NO. 69094 |
| DWG. NO. P-13834 PRODUCT NO. Z-181-77 |               |                |

\*REGULARLY FURNISHED UNLESS OTHERWISE SPECIFIED