



Z100-95

SPECIFICATION SHEET

20 [508] WIDE DECK FLANGE ROOF DRAIN W/ MESH SCREEN STRAINER AND 2" WATER DAM

TAG _____

Dimensional Data (inches and [mm]) are Subject to Manufacturing Tolerances and Change Without Notice

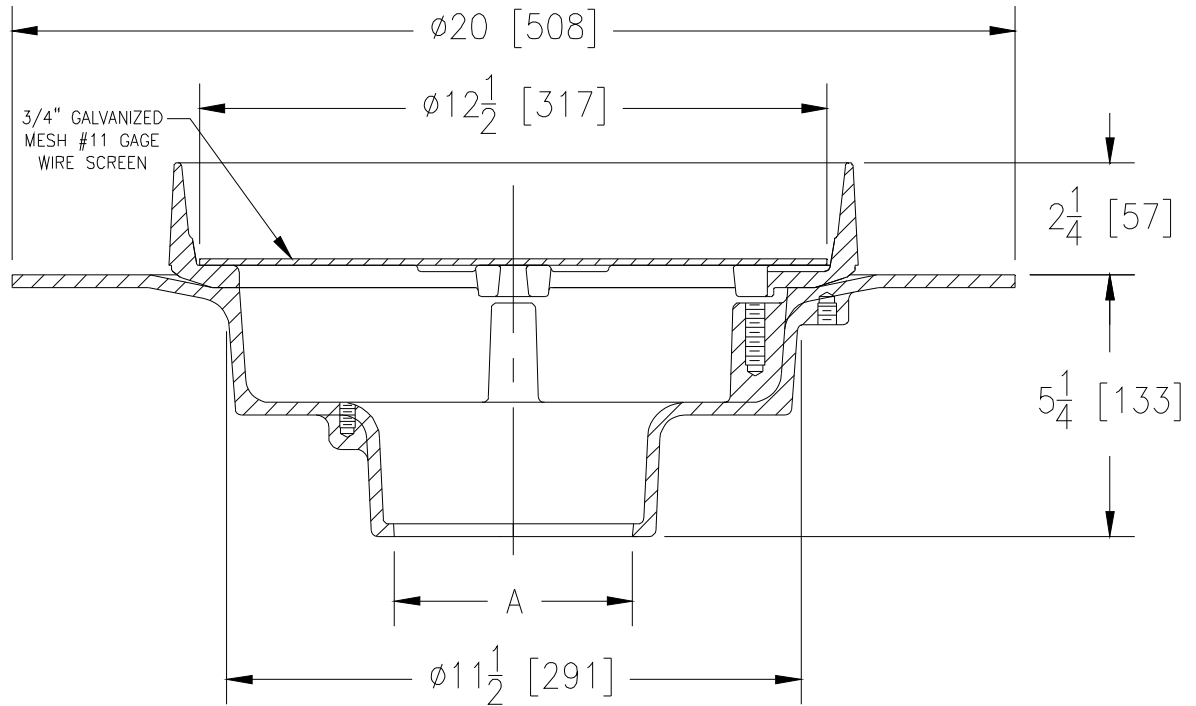

A Pipe Size In.	Approx. Wt. Lbs. [kg]
2,3,4 [51,76,102]	26 [12]
5,6 [127,152]	27 [12]
8 [203]	28 [13]

ENGINEERING SPECIFICATION: ZURN Z100-95

20 [508] Diameter roof drain. Dura-Coated cast iron wide flange body with combination membrane flashing clamp/2 [50] high external water dam and mesh wire screen strainer.

OPTIONS (Check/specify appropriate options)

PIPE SIZE

2 thru 6,8 [51 thru 152,203]
2 thru 6,8 [51 thru 152,203]

(Specify size/type) OUTLET

____ IC Inside Caulk
____ NH No-Hub

E BODY HT. DIM.

5 1/4 [133]
5 1/4 [133]

PREFIXES

____ Z D.C.C.I. Body and Grate*

SUFFIXES

____ -AC Angular Underdeck Clamp
 ____ -AR Acid Resistant Epoxy Coated
 ____ -C Underdeck Clamp
 ____ -E Static Extension 1 [25] thru 4 [102] (Specify Ht.)
 ____ -EA Adjustable Extension Assembly
 2 1/8 [54] thru 3 1/2 [89]
 ____ -VP Vandal-Proof Secured Top
 ____ -84 Stainless Steel Perforated Gravel Guard
 ____ -90 90° Threaded Side Outlet Body
 (2 thru 6 [51 or 152])

REV. A DATE: 08/09/10 C.N. NO. 111477

DWG. NO. P-13498 PRODUCT NO. Z100-95

*REGULARLY FURNISHED UNLESS OTHERWISE SPECIFIED

ZURN INDUSTRIES, LLC ♦ SPECIFICATION DRAINAGE OPERATION ♦ 1801 Pittsburgh Ave. ♦ Erie, PA 16514

Phone: 814/455-0921 ♦ Fax: 814/454-7929 ♦ World Wide Web: www.zurn.com

In Canada: ZURN INDUSTRIES LIMITED ♦ 3544 Nashua Drive ♦ Mississauga, Ontario L4V1L2 ♦ Phone: 905/405-8272 Fax: 905/405-1292