



# Z100-120

15 [381] DIAMETER MAIN ROOF DRAIN  
WITH 10 [254] PROM DECK DRAIN

SPECIFICATION SHEET

TAG \_\_\_\_\_

Dimensional Data (inches and [ mm ]) are Subject to Manufacturing Tolerances and Change Without Notice

A- Pipe Size In.	Approx. Wt. Lbs.	Grate Open Area Sq. In.	Dome Open Area Sq. In.
2,3,4 [51,76,102]	49 [22]	21 [135]	103 [665]
6 [152]	50 [23]	21 [135]	103 [665]
8 [203]	51 [23]	21 [135]	103 [665]

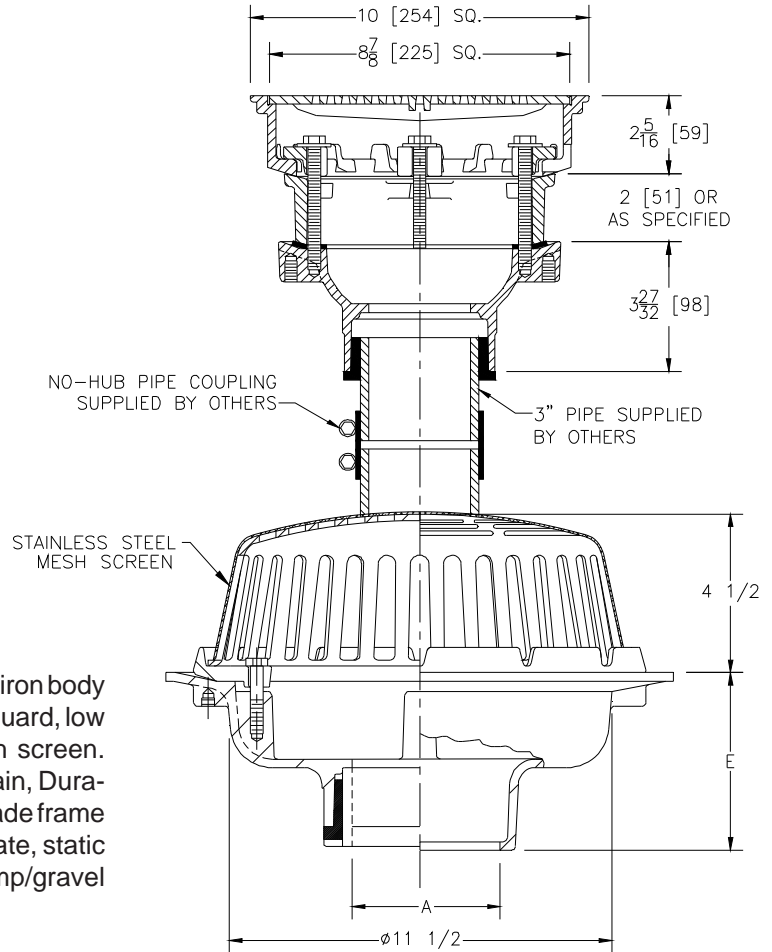

### ENGINEERING SPECIFICATION: ZURN Z100-120

15" [381mm] Diameter Roof Drain Dura-Coated cast iron body with combination membrane flashing clamp/gravel guard, low silhouette cast iron dome with stainless steel mesh screen. Upper body consists of 10" [254mm] Prom-Deck drain, Dura-Coated cast iron body with rotatable square promenade frame with seepage openings and light duty heel-proof grate, static extension and combination membrane flashing clamp/gravel guard.

### OPTIONS (Check/specify appropriate options)

#### PIPE SIZE

- 3, 4, 6 [76,102,152]
- 2, 3, 4, 6, 8 [51,76,102,152,203]
- 2, 3, 4, 6, 8 [51,76,102,152,203]
- 2, 3, 4 [51,76,102]
- 6 [152]

#### (Specify size/type) OUTLET

- \_\_\_\_\_ IC Inside Caulk
- \_\_\_\_\_ IP Threaded
- \_\_\_\_\_ NH No-Hub
- \_\_\_\_\_ NL Neo-Loc
- \_\_\_\_\_ NL Neo-Loc

#### 'E' BODY HT. DIM.

- 5-1/4 [133]
- 3-3/4 [95]
- 5-1/4 [133]
- 4-9/16 [116]
- 5-7/16 [112]

#### PREFIXES

- \_\_\_\_\_ Z D.C.C.I. Body with Top\*
- \_\_\_\_\_ ZB D.C.C.I. Body with Polished Bronze Top (Add 3/16 [5] to 2-1/4 [57] Dim & 5/8 [16] to 10 [254] Dim)
- \_\_\_\_\_ ZN D.C.C.I. Body with Polished Nickel Bronze Top (Add 3/16 [5] to 2-1/4 [57] Dim & 5/8 [16] to 10 [254] Dim)

#### SUFFIXES

- \_\_\_\_\_ -AR Acid Resistant Epoxy Coated
- \_\_\_\_\_ -C Underdeck Clamp (Lower Body)
- \_\_\_\_\_ -DP Top-Set® Deck Plate (Replaces both the -C and -R, Lower Body)
- \_\_\_\_\_ -G Galvanized Cast Iron
- \_\_\_\_\_ -R Roof Sump Receiver (Lower Body)

\* Regularly furnished unless otherwise specified.