



Z100-205

SPECIFICATION SHEET

15 [381] DIAMETER MAIN ROOF DRAIN W/ STAINLESS MESH SCREEN, STANDPIPE AND UPPER Z100-SS

TAG _____

Dimensional Data (inches and [mm]) are Subject to Manufacturing Tolerances and Change Without Notice

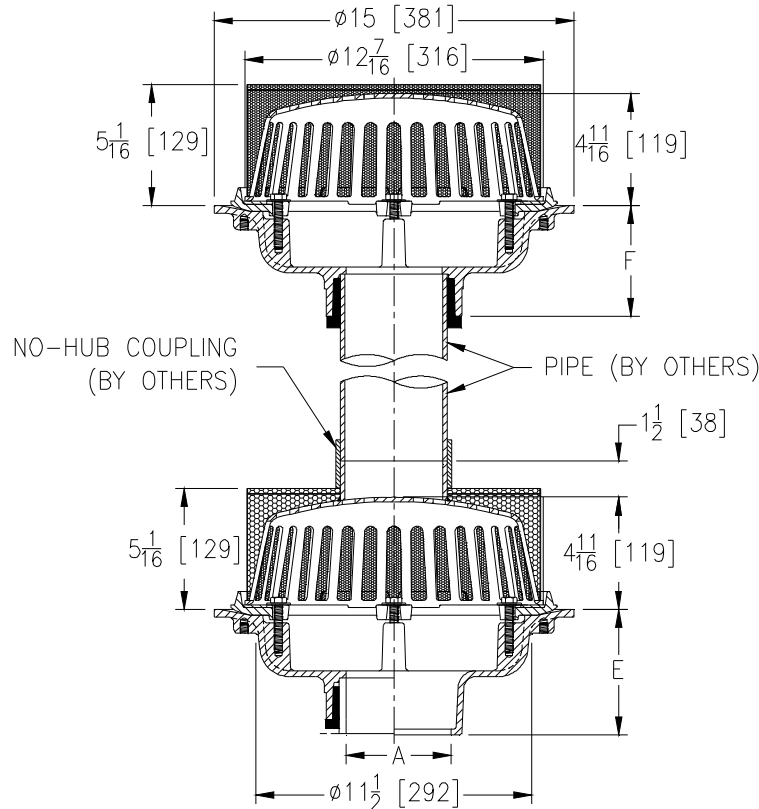

A Pipe Size In.	Approx. Wt. Lbs. [kg]	Dome Open Area Sq. In. [cm ²]
2,3,4 [51,76,102]	54 [24]	103 [665]
5,6 [127,152]	52 [24]	

ENGINEERING SPECIFICATION: ZURN Z100-205

15 [381] Diameter roof drain. Dura-Coated cast iron body with combination membrane flashing clamp/gravel guard, low silhouette cast iron dome with stainless mesh screen, no-hub coupling and standpipe (by others) and upper Z100-SS.

OPTIONS (Check/specify appropriate options)

PIPE SIZE

- 2 thru 6,8 [51 thru 152,203]
- 2 thru 6,8 [51 thru 152,203]
- 2 thru 6,8 [51 thru 152,203]
- 2,3,4 [51,76,102]
- 6 [152]

(Specify size/type) OUTLET

- _____ IC Inside Caulk
- _____ IP Threaded
- _____ NH No-Hub
- _____ NL Neo-Loc
- _____ NL Neo-Loc

E BODY HT. DIM.

- 5 1/4 [133]
- 3 3/4 [95]
- 5 1/4 [133]
- 4 9/16 [116]
- 5 7/16 [112]

F BODY HT. DIM.

-
-
-
- 4 9/16 [116]
- 5 7/16 [112]

PREFIXES

- _____ ZA D.C.C.I. Body with Aluminum Dome
- _____ ZC D.C.C.I. Body with Cast Iron Dome*
- _____ ZRB D.C.C.I. Body with Plain Bronze Dome

SUFFIXES

- _____ -AC Angular Underdeck Clamp (lower body)
- _____ -AR Acid Resistant Epoxy Coated
- _____ -C Underdeck Clamp (lower body)
- _____ -DX Dex-o-tex Flange
- _____ -G Galvanized Cast Iron
- _____ -GD Galvanized Cast Iron Dome (ZC Only)
- _____ -R Roof Sump Receiver (lower body)
- _____ -SC Secondary Clamp Collar
- _____ -TC Neo-Loc Test Cap Gasket (lower body)
(2 - 4 [51 - 102] NL Bottom Outlet Only)
- _____ -VP Vandal-Proof Secured Top
- _____ -84 Stainless Steel Perforated Gravel Guard
- _____ -89 2 [51] High External Water Dam
- _____ -90 90° Threaded Side Outlet Body
(2 thru 6 [51 or 152]) (lower body)

*REGULARLY FURNISHED UNLESS OTHERWISE SPECIFIED

REV.	DATE: 7/21/09	C.N. NO. 109993
DWG. NO. P-15736 PRODUCT NO. Z100-205		

ZURN INDUSTRIES, LLC ♦ SPECIFICATION DRAINAGE OPERATION ♦ 1801 Pittsburgh Ave. ♦ Erie, PA 16514

Phone: 814/455-0921 ♦ Fax: 814/454-7929 ♦ World Wide Web: www.zurn.com

In Canada: ZURN INDUSTRIES LIMITED ♦ 3544 Nashua Drive ♦ Mississauga, Ontario L4V1L2 ♦ Phone: 905/405-8272 Fax: 905/405-1292