



Z520-91

9 [229] DIA. ADJUSTABLE HEAVY-DUTY DRAIN W/ ACID RESISTANT EPOXY COATING & TRAP PRIMER CONNECTION

SPECIFICATION SHEET

TAG _____

Dimensional Data (inches and [mm]) are Subject to Manufacturing Tolerances and Change Without Notice

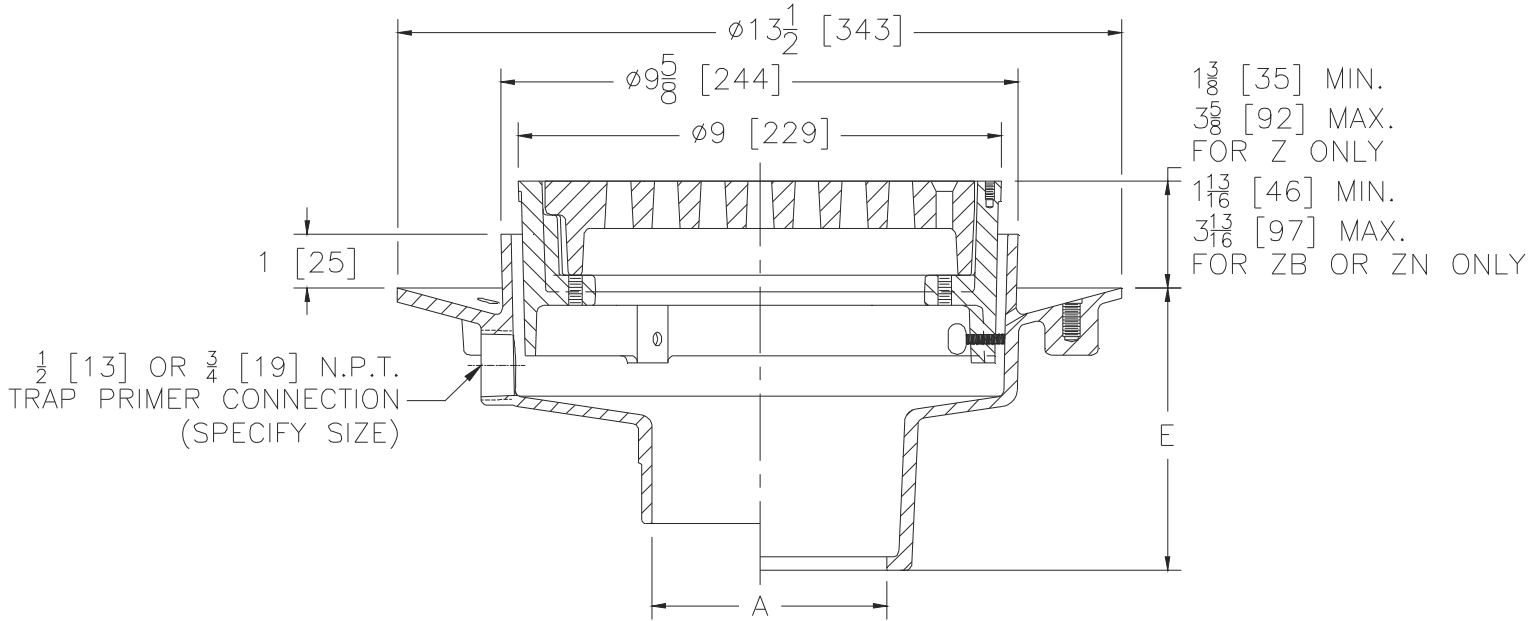

A Pipe Size In. [mm]	Approx. Wt. Lbs. [kg]	Grate Open Area Sq. In. [cm ²]
2, 3, 4 [51, 76, 102]	39 [18]	18[116]
6 [152]	44 [20]	

ENGINEERING SPECIFICATION: ZURN Z520-91

9" [229mm] Diameter top drain, acid resistant epoxy coated cast iron body with bottom outlet, seepage pan, trap primer connection, and adjustable extension frame with heavy-duty cast iron deep flange slotted grate. Note: Acid resistant epoxy coating not recommended on this product due to design of set screws, which could damage coating.

OPTIONS (Check/specify appropriate options)

PIPE SIZE

- 2, 3, 4 [51, 76, 102]
- 2, 3, 4 [51, 76, 102]
- 2, 3, 4 [51, 76, 102]
- 2, 3, 4, 6 [51, 76, 102, 152]
- 2, 3, 4 [51, 76, 102]

(Specify size/type) OUTLET

- ___ IC Inside Caulk
- ___ IG Inside Gasket
- ___ IP Threaded
- ___ NH No-Hub
- ___ NL Neo-Loc

'E' DIM.

- 5-1/4 [133]
- 5-1/4 [133]
- 3-1/2 [89]
- 4-1/4 [108]
- 4-3/8 [111]

PREFIXES

- ___ Z Acid Resistant Epoxy Coated Body and Top*
- ___ ZB Acid Resistant Epoxy Coated Body w/ Polished Bronze Top (Add 5/8 [16] to 9 [229] Dim.)
- ___ ZN Acid Resistant Epoxy Coated Body w/ Polished Nickel Bronze Top (Add 5/8 [16] to 9 [229] Dim.)

SUFFIXES

- ___ -C Clamp Collar
- ___ -DG Duresist Grate
- ___ -F Extension Frame (Specify Total Height Req'd)
- ___ -HP Heel-Proof Grate
- ___ -S Secondary Strainer
- ___ -SC Solid Cover
- ___ -SG Solid Gasketed Cover
- ___ -SS Stainless Mesh Liner for Bucket
- ___ -T Square Top
- ___ -TC Neo-Loc Test Cap Gasket (2, 3, 4 [51, 76, 102] NL Bottom Outlet Only)
- ___ -TS Top Secured with Slotted Screws
- ___ -V Backwater Valve (See Z1099)
- ___ -VP Vandal-Proof Secured Top
- ___ -Y Sediment Bucket
- ___ -90 90° Side Outlet (See Z1042)

* Regularly furnished unless otherwise specified.