



# Z100-DR-EA

15 [381] DIAMETER MAIN ROOF DRAIN W/ TOP-SET® STRAINER AND ADJUSTABLE EXTENSION

SPECIFICATION SHEET

TAG \_\_\_\_\_

Dimensional Data (inches and [ mm ]) are Subject to Manufacturing Tolerances and Change Without Notice

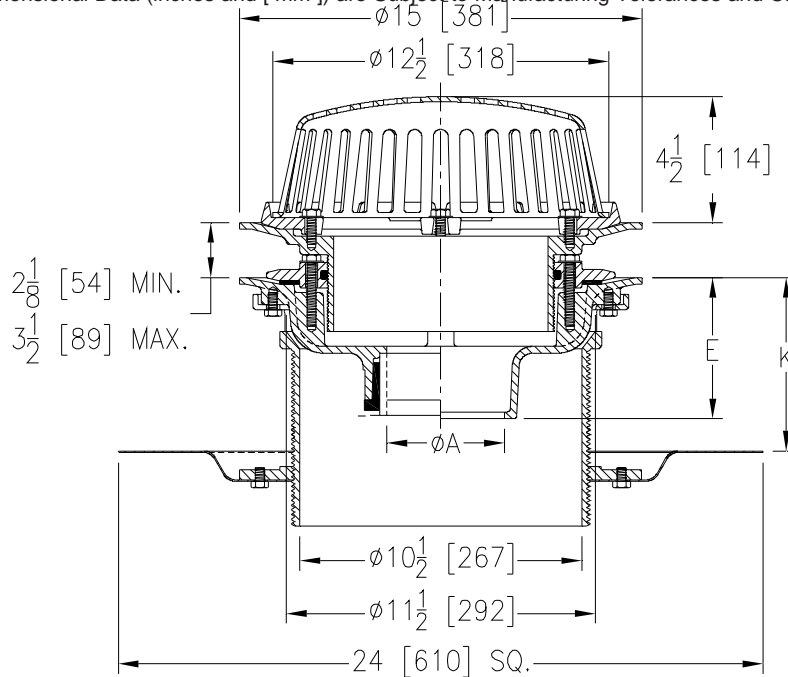

A Pipe Size in [mm]	Approx Wt. lbs [kg]	Dome Open Area in <sup>2</sup> [cm <sup>2</sup> ]
2,3,4 [51,76,102]	35 [16]	103 [665]
6 [152]	36 [16]	
8 [203]	37 [17]	

**ENGINEERING SPECIFICATION: ZURN Z100-DR-EA**  
 15" [381mm] Diameter roof drain. Dura-Coated cast iron body with combination membrane flashing clamp/gravel guard, Top-Set® drain riser, adjustable extension assembly and low silhouette Poly-Dome.

**OPTIONS** (Check/specify appropriate options)

**PIPE SIZE**

- 3,4,6 [76,102,152]
- 2,3,4,6,8 [51,76,102,152,203]
- 2,3,4,6,8 [51,76,102,152,203]
- 2,3,4 [51,76,102]
- 6 [152]

(Specify size/type) **OUTLET**

- \_\_\_\_\_ IC Inside Caulk
- \_\_\_\_\_ IP Threaded
- \_\_\_\_\_ NH No-Hub
- \_\_\_\_\_ NL Neo-Loc
- \_\_\_\_\_ NL Neo-Loc

**E BODY HT. DIM.**

- 5-1/4 [133]
- 3-3/4 [95]
- 5-1/4 [133]
- 4-5/8 [117]
- 5-7/16 [138]

**PREFIXES**

- \_\_\_\_\_ Z D.C.C.I. Body with Poly-Dome\*
- \_\_\_\_\_ ZA D.C.C.I. Body with Aluminum Dome
- \_\_\_\_\_ ZC D.C.C.I. Body with Cast Iron Dome
- \_\_\_\_\_ ZRB D.C.C.I. Body with Plain Bronze Dome

**SUFFIXES**

- |   |   |
|---|---|
| _____ -AR Acid Resistant Epoxy Coated   | _____ -ST Dome w/ Solid Top (ZA and ZC Only)                                |
| _____ -AW 3/4 [19] to 4 [102] Adjustable Water Level Regulator (Specify Height) (ZC Only) | _____ -TC Neo-Loc Test Cap Gasket (2,3,4 [51,76,102] NL Bottom Outlet Only) |
| _____ -E Static Extension 1 [25] thru 4 [102] (Specify Ht.)                               | _____ -VP Vandal Proof Secured Top  |
| _____ -FG Flush Grate (Replaces Dome Strainer)  | _____ -W2 2 [51] Internal Water Dam   |
| _____ -G Galvanized Cast Iron   | _____ -W3 3 [76] Internal Water Dam   |
| _____ -HD 6-3/4 [171] High Aluminum Dome (148 sq. in. [955 cm <sup>2</sup> ] open area)   | _____ -W4 4 [102] Internal Water Dam  |
| _____ -SC Secondary Clamping Collar   | _____ -84 Stainless Steel Perforated Gravel Guard                           |
| _____ -SS Stainless Mesh Screen Over Dome   | _____ -85 Stainless Steel Perforated Extension                              |
|   | _____ -89 2 [51] High External Water Dam                                    |

\* Regularly furnished unless otherwise specified.