



ZN1910-KC

8-9/16 x 8-9/16 [217 x 217] A.R.E. SANI-FLORECEPTOR 6
 [152] SUMP DEPTH WITH SEEPAGE FLANGE, CLAMP
 COLLAR, AND NICKEL BRONZE FRAME AND GRATE

SPECIFICATION SHEET

TAG _____

Dimensional Data (inches and [mm]) are Subject to Manufacturing Tolerances and Change Without Notice

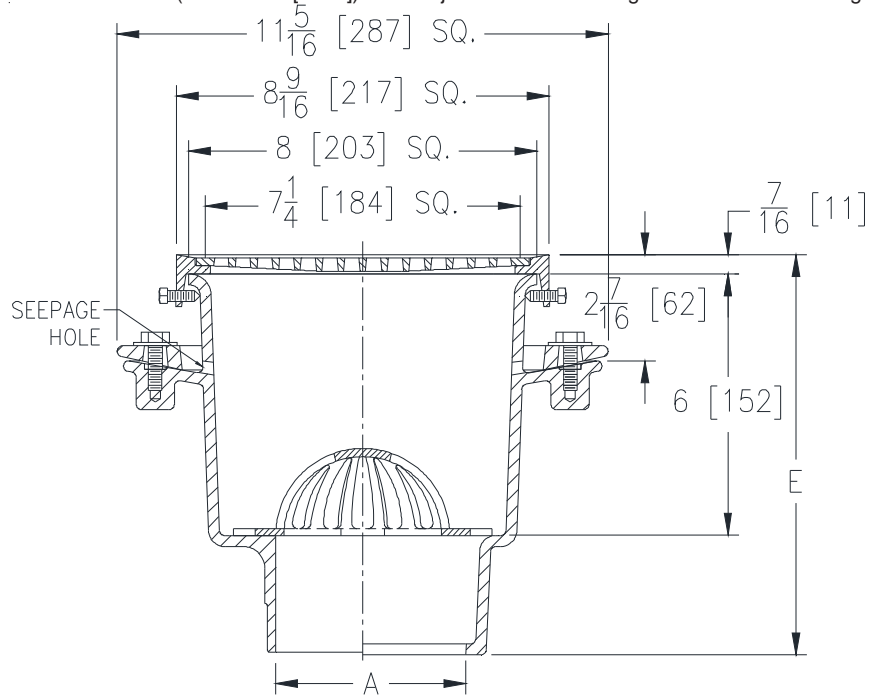

A Pipe Size In. [mm]	Approx Wt. Lbs. [kg]	Grate Open Area Sq. In. [cm ²]
2,3,4 [51,76,102]	25 [11]	19 [123]

ENGINEERING SPECIFICATION: ZURN ZN1910-KC

Sani-Floreceptor 8-9/16" x 8-9/16" x 6" [217mm x 217mm x 152mm] deep cast iron body with Seepage flange with seepage holes with clamp collar, white acid resisting porcelain enamel interior and top, square nickel bronze frame and full grate, complete with white ABS anti-splash interior bottom dome strainer.

OPTIONS (Check/specify appropriate options)

PIPE SIZE

- 3,4 [76,102]
- 2,3,4 [51,76,102]
- 2,3,4 [51,76,102]

(Specify size/type) OUTLET

- ___ IC Inside Caulk
- ___ NH No-Hub
- ___ NL Neo-Loc

'E' BODY HT. DIMENSION

- 9-3/16 [233]
- 9-1/16 [230]
- 8-7/16 [214]

PREFIXES

- ___ ZN Cast Iron Body with White A.R.E. Interior, 8-9/16 [217] Square N.B. Frame and Full Grate with 5/16 [8] Square Openings *

SUFFIXES

- | | | | |
|---------|--|---------|---|
| ___ -DX | Dex-o-Tex Flange | ___ -11 | Vandal-Proof Secured Grate |
| ___ -LD | Less Bottom Dome Strainer | ___ -15 | Solid Loose Set Cover |
| ___ -P | 1/2 [13] Trap Primer Connection (See Z1023) | ___ -19 | Full Hinged Grate |
| ___ -TC | Neo-Loc Test Cap Gasket
(2,3,4 [51,76,102] NL Bottom Outlet Only) | ___ -23 | Aluminum Bucket |
| ___ -1 | Less Grate | ___ -25 | White A.R.C. Bucket |
| ___ -2 | 1/2 Grate | ___ -31 | Stainless Steel Mesh Liner for Bucket |
| ___ -3 | 3/4 Grate | ___ -32 | Aluminum Dome Strainer |
| ___ -4 | Full Grate with Square Center Opening | ___ -33 | White A.R.C. Anti-Splash Bottom Dome Strainer |
| ___ -6 | Grate w/ 6 [152] Dia. x 6 [152] High Funnel | | |
| ___ -8 | Grate w/ 8-7/8 x 3-5/8 x 3-3/4 [225 x 92 x 95] High Oval Funnel | | |

* Regularly furnished unless otherwise specified.

Zurn Industries, LLC | Specification Drainage Operation
 1801 Pittsburgh Avenue, Erie, PA U.S.A. 16502 · Ph. 855-663-9876, Fax 814-454-7929
 In Canada | Zurn Industries Limited
 3544 Nashua Drive, Mississauga, Ontario L4V 1L2 · Ph. 905-405-8272, Fax 905-405-1292
www.zurn.com

Rev. -
 Date: 10/13/17
 C.N. No. 138843
 Prod. | Dwg. No. ZN1910-KC