



Z882-SW2

12 [305] WIDE REVEAL TRENCH DRAIN SYSTEM WITH STEEL FRAME AND DOUBLE SIDEWALL EXTENSIONS

TAG _____

Dimensional Data (inches and [mm]) are Subject to Manufacturing Tolerances and Change Without Notice

SPECIFYING ENGINEER IS RESPONSIBLE FOR CONCRETE ENCASEMENT AND REINFORCING BASED UPON APPLICATION AND LOCAL CODES

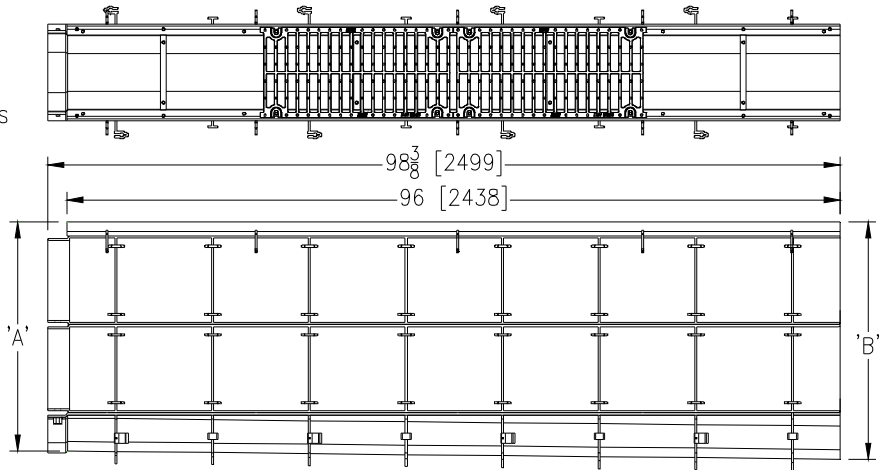
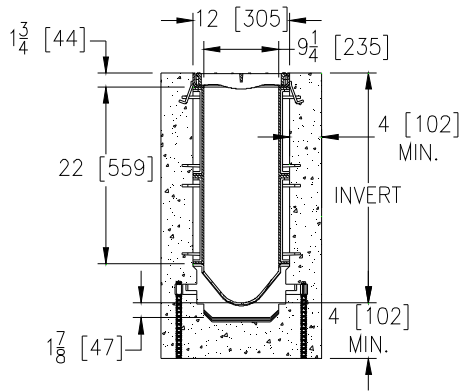

Note: + Actual Channel length is 98 3/8 [2499] to allow for overlap.

ENGINEERING SPECIFICATION: Zurn Z882-SW2

Channels shall be 96 [2438] long, 12 [305] wide reveal and have a 9-1/4 [235] throat. Modular channel sections shall be made of 0% water absorbent High Density Polyethylene (HDPE). Shall have a positive mechanical connection between channel sections that will not separate during the installation and shall mechanically lock into the concrete surround every 12 [305]. Channels shall weigh less than 5.05 lbs. [2.29kg] per linear foot, have a smooth, 3 [76] radiused self cleaning bottom with a Manning's coefficient of .009 and 1.04% or neutral 0% built in slope. Channels shall have HDPE SW2 Walls provided for an additional 22 [559] added to the standard channel invert for additional flow capability shown in chart below. Channels shall have rebar clips standard to secure trench in its final location. Shall be provided with standard DGC grates that lock down to frame. Zurn 12 [305] wide reveal Ductile Iron Slotted Grate conforming to ASTM specification A536-84, Grade 80-55-06. Ductile Iron grate is rated class C per the DIN EN1433 top load classifications. Supplied in 24 [608] nominal lengths with 63/64 [25] wide slots, and 1-1/2 [38] bearing depth. Grate has an open area of 80.8sq. in per ft. [171,027 sq. mm per meter] The 1/4 [6] thick Heavy-Duty Carbon Steel Frame Assembly conforms to ASTM specification A36 with 10 - 4 [102] long concrete anchors per 96 [2438]. Grate lockdown bars are to be integral to the frame The frame is supplied with a powder coated finish. All welds must be performed by a certified welder per ASTM standard AWS D1.1. Frames Shall be produced in the U.S.A.

Trench No.	'A' Shallow Inv.	'B' Deep Inv.	Flow		
			(cfs)	(gpm)	(lps)
8202 SW2	29.25 [743]	30.25 [768]	13.79	6192	391
8203 SW2	30.25 [768]	31.25 [794]	14.35	6442	406
8203N SW2	31.25 [794]	31.25 [794]	-	-	-
8204 SW2	31.25 [794]	32.25 [819]	14.91	6692	422
8205 SW2	32.25 [819]	33.25 [845]	15.47	6942	438
8206 SW2	33.25 [845]	34.25 [870]	16.02	7192	454
8206N SW2	34.25 [870]	34.25 [870]	-	-	-
8207SW2	34.25 [870]	35.25 [895]	16.58	7442	469
8208 SW2	35.25 [895]	36.25 [921]	17.14	7692	485
8209 SW2	36.25 [921]	37.25 [946]	17.69	7942	501
8209N SW2	37.25 [946]	37.25 [946]	-	-	-
8210 SW2	37.25 [946]	38.25 [972]	18.25	8192	517
8211 SW2	38.25 [972]	39.25 [997]	18.81	8442	533
8212 SW2	39.25 [997]	40.25 [1022]	19.36	8692	548

*REGULARLY FURNISHED UNLESS OTHERWISE SPECIFIED



Z882-SW2

12 [305] WIDE REVEAL TRENCH DRAIN SYSTEM WITH STEEL FRAME AND DOUBLE SIDEWALL EXTENSIONS

TAG _____

Dimensional Data (inches and [mm]) are Subject to Manufacturing Tolerances and Change Without Notice

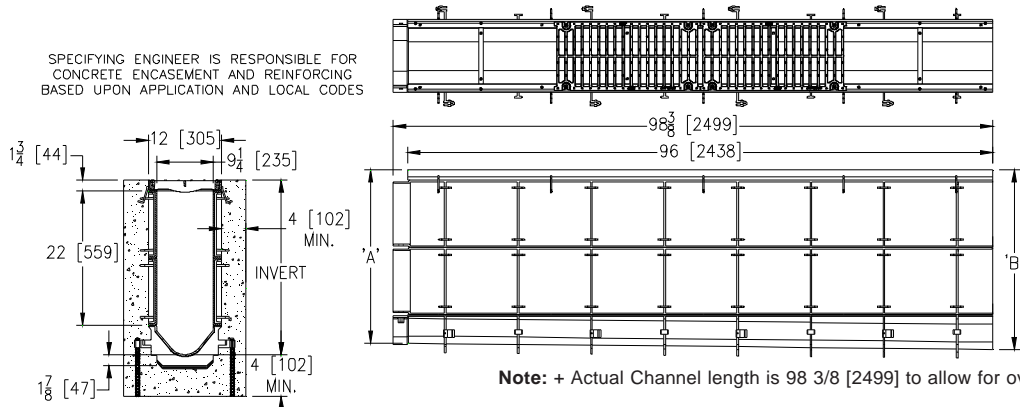

PREFIX OPTIONS (Check/specify appropriate options)

- ___ Z z882-High Density Polyethylene (HDPE) Channel, Heavy-Duty Frame with Anchor Studs.*

SUFFIX OPTIONS (Check/specify appropriate options)

Outlet Adapters Add/Each

- ___ -E1 Closed End Cap
- ___ -E4 4 [102] No-Hub End Outlet
- ___ -E6 6 [152] No-Hub End Outlet
- ___ -E8 8 [203] No-Hub End Outlet
- ___ -U4 4 [102] No-Hub Bottom Outlet
- ___ -U6 6 [152] No-Hub Bottom Outlet
- ___ -U8 8 [203] No-Hub Bottom Outlet

Grate Options (Load Classifications are per DIN EN1433)

- ___ -BDC Black Acid Resistant Epoxy Coated Ductile Grate - Class C
- ___ -BDE Black Acid Resistant Epoxy Coated Ductile Grate - Class E
- ___ -BDF Black Acid Resistant Epoxy Coated Ductile Grate - Class F
- ___ -BG Galvanized Steel Bar Grate - Class D
- ___ -DC Ductile Iron Solid Cover - Class C
- ___ -DGC Ductile Iron Slotted Grate - Class C *
- ___ -DGE Ductile Iron Slotted Grate - Class E
- ___ -DGF Ductile Iron Slotted Grate - Class F
- ___ -GDC Galvanized Ductile Slotted Grate - Class C
- ___ -GDE Galvanized Ductile Slotted Grate - Class E
- ___ -GDF Galvanized Ductile Slotted Grate - Class F
- ___ -GG Fiberglass Grate - Class A
- ___ -GHPD Galvanized Heel-Proof Ductile Grate - Class C
- ___ -GHPDE Galvanized Heel-Proof Ductile Slotted Grate - Class E
- ___ -HPD Heel-Proof Ductile Slotted Grate - Class C
- ___ -HPDE Heel-Proof Ductile Slotted Grate - Class E
- ___ -RFGC Reinforced Slotted Galvanized Grate - Class C
- ___ -RPGC Reinforced Perforated Galvanized Grate - Class C
- ___ -RPGRC Reinforced Perforated Galvanized Reverse Punch Grate - Class C
- ___ -RFSC Reinforced Slotted Stainless Steel Grate - Class C
- ___ -RPSC Reinforced Perforated Stainless Steel Grate - Class C
- ___ -RPSRC Reinforced Perforated Stainless Steel Reverse Punch Grate - Class C

MADE in the U.S.A.

- ___ -ADA-USA Meets Americans with Disabilities Act Requirements - Class C
- ___ -BDE-USA Black Acid Resistant Epoxy Coated Ductile Grate - Class E
- ___ -DGC-USA Ductile Iron Slotted Grate - Class C
- ___ -DGE-USA Ductile Iron Slotted Grate - Class E
- ___ -FG Fabricated Galvanized Steel Slotted Grate - Class A
- ___ -FS Fabricated Stainless Steel Slotted Grate - Class A
- ___ -GADA-USA Galvanized Ductile ADA Slotted Grate - Class C
- ___ -GDC-USA Galvanized Ductile Slotted Grate - Class C
- ___ -GDE-USA Galvanized Ductile Slotted Grate - Class E
- ___ -GHPDE-USA Galvanized Ductile Slotted Grate - Class E
- ___ -HPDE-USA Heel-Proof Ductile Slotted Grate - Class E
- ___ -PG Perforated Galvanized Steel Grate - Class A
- ___ -PGR Galvanized Perforated Reverse Punch Anti-Slip ADA Grate - Class A
- ___ -PS Perforated Stainless Steel Grate - Class A
- ___ -PSR Stainless Steel Perforated Reverse Punch Anti-Slip ADA Grate - Class A
- ___ -RFG Reinforced Galvanized Slotted Grate - Class B
- ___ -RFS Reinforced Stainless Steel Slotted Grate - Class B
- ___ -RPG Reinforced Galvanized Perforated Grate - Class B
- ___ -RPGRC Reinforced Galvanized Perforated Reverse Punch Anti-Slip ADA Grate - Class B
- ___ -RPS Reinforced Stainless Steel Perforated Grate - Class B
- ___ -RPSR Reinforced Stainless Steel Perforated Reverse Punch Anti-Slip ADA Grate - Class B
- ___ -SBG-L Stainless Steel Bar Grate - Class C
- ___ -SSCD Reinforced Stainless Steel Solid Cover - Class B

Miscellaneous Options

- ___ -DB Bottom Dome Strainer
- ___ -CBF Black Acid Resistant Coated Top Frame
- ___ -JC Joint Connector
- ___ -VP Vandal-Proof Lockdown

*REGULARLY FURNISHED UNLESS OTHERWISE SPECIFIED