



Z1183-FC-77

SPECIFICATION SHEET

SOLIDS INTERCEPTOR W/ INTEGRAL EXTENSION, FLUSH COVER, ANCHOR FLANGE & DEX-O-TEX FLANGE TAG _____

Dimensional Data (inches and [mm]) are Subject to Manufacturing Tolerances and Change Without Notice

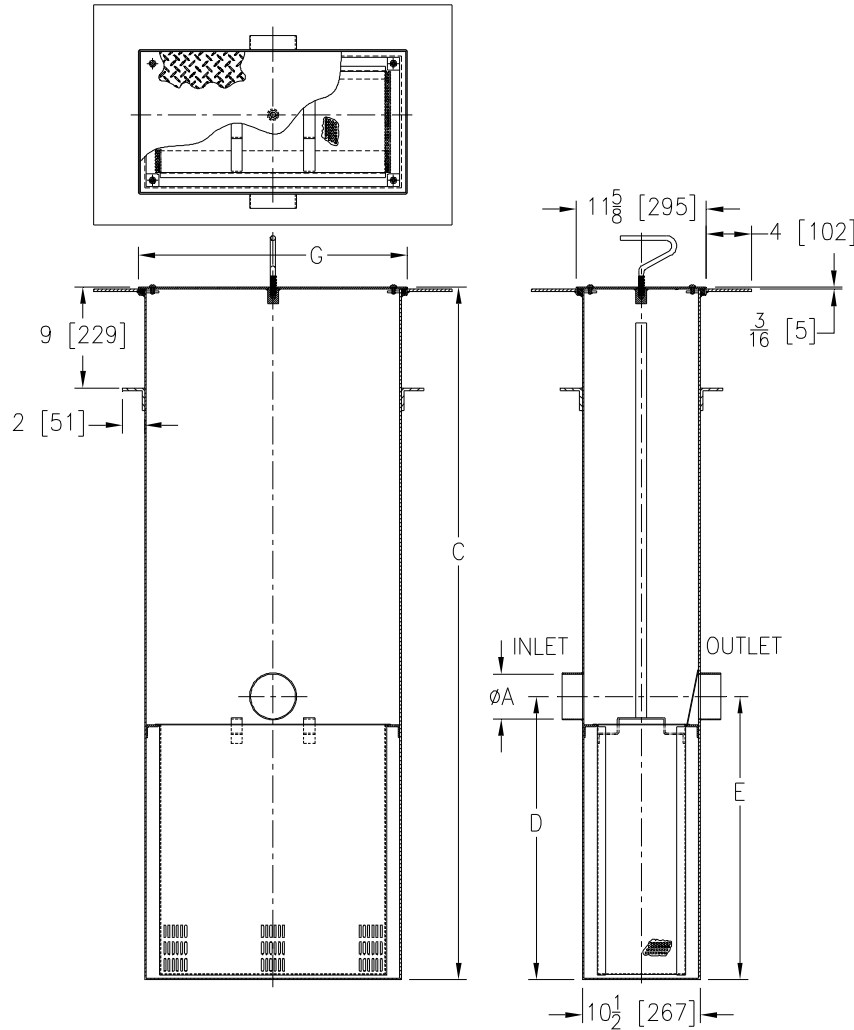

Size	'A' Inlet/Outlet Size	Flow Rate G.P.M. [L]	Solids Cap. Cubic Ft. [m ³]	Dimensions In Inches		
				C	G	D/E
1200	4 [102]	150 [568]	2.59 [.073]	62 7/8 [1597]	24 3/8 [619]	25 1/4 [641]

ENGINEERING SPECIFICATION: ZURN Z1183-FC-77

Large capacity acid resistant coated interior and exterior fabricated steel, or stainless steel solids interceptor with integral extension, anchor flange and dex-o-tex flange for recessed installation with perforated filter screen, gasketed, non-skid secured cover with removable lift handle, and removable sediment basket. Size to be used with corresponding Z1172 Grease Interceptor.

OPTIONS (Check/specify appropriate option)

PREFIXES

- ___ Z Acid Resistant Coated Fabricated Steel*
- ___ ZS Type 304 Fabricated Stainless Steel

SUFFIXES

- ___ -CS Custom Screens (Specify material and perforation size required)
- ___ -YR Replacement Stainless Steel Bucket Assembly

*REGULARLY FURNISHED UNLESS OTHERWISE SPECIFIED

REV.	DATE: 1/13/09	C.N. NO. 99570
DWG. NO. P-15647	PRODUCT NO. Z1183-FC-77	