



Z1170-111

ADJUSTABLE RECESSING RECEIVER FOR GREASE INTERCEPTOR WITH FLOW CONTROL FITTING

SPECIFICATION SHEET

TAG _____

Dimensional Data (inches and [mm]) are Subject to Manufacturing Tolerances and Change Without Notice

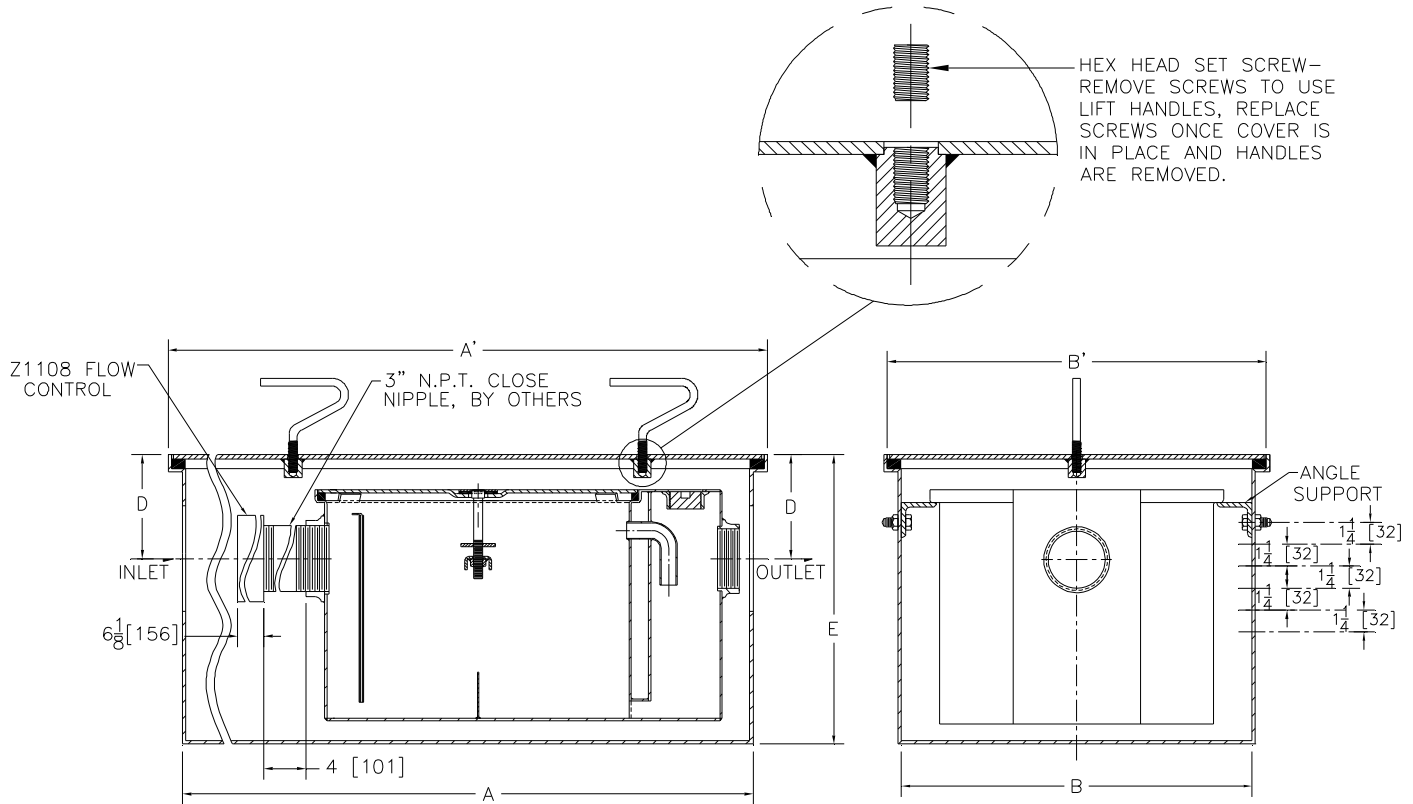

Size	Dimensions in Inches					
	A	A'	B	B'	D	E
500	47 [1194]	49 [1245]	20 3/4 [527]	22 5/8 [575]	5 1/4 [133]	22 3/4 [578]
700	51 [1295]	53 [1346]	26 [660]	27 7/8 [708]	6 9/16 [167]	27 3/4 [705]
800	53 1/4 [1353]	55 1/4 [1403]	28 [711]	29 7/8 [759]	7 1/2 [191]	30 1/2 [775]

ENGINEERING SPECIFICATION: ZURN Z1170-111 Acid Resistant Epoxy Coated Recessing receiver equipped with adjustable support brackets and gasketed non-skid cover with removable lift handles. Complete with Z1170 Grease interceptor and Z1108 flow control fitting. For grease interceptor specifications see Z1170 specification sheet.

PREFIXES

___ Z Acid Resistant Coated Fabricated Steel*

SUFFIXES

- ___ -K Anchor flange 1 3/4 [44] down from top and 2 [51] wide. A 3 [76] minimum extension height is required when anchor flange (-K) option is specified.
- ___ -KC Anchor flange 1 3/4 [44] down from top and 2 [51] wide with clamp collar. A 3 [76] minimum extension height is required when anchor flange (-KC) option is specified.

REV. B DATE: 03/01/11 C.N. NO. 120951
 DWG. NO. P-15105 PRODUCT NO. Z1170-111

*REGULARLY FURNISHED UNLESS OTHERWISE SPECIFIED