



Z415J-77

SPECIFICATION SHEET

BODY ASSEMBLY W/ 4[102] X 12[305] GUTTER DRAIN, ADJUSTABLE STANDPIPE, AND DEX-O-TEX FLANGE

TAG _____

Dimensional Data (inches and [mm]) are Subject to Manufacturing Tolerances and Change Without Notice

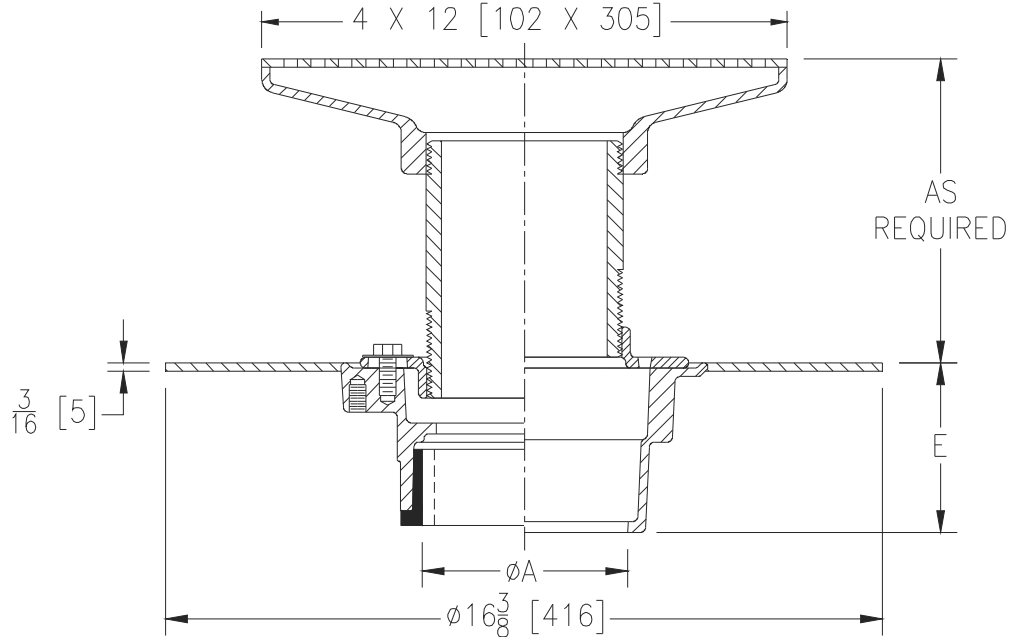

Dimensions In Inches	Approx. Wt. Lbs. [kg]	Strainer Open Area Sq. In. [cm ²]
A - Pipe Size		
2-3-4 [51-76-102]	25 [6]	13 [116]

ENGINEERING SPECIFICATION: ZURNZ415J-77

Dura-Coated cast iron body with bottom outlet, combination invertible membrane clamp, Dex-O-Tex flange, 4[102] X 12[305] Stainless Steel Gutter Drain, and adjustable standpipe.

OPTIONS (Check/specify appropriate options)

PIPE SIZE

- 2 - 4 [51-102]
- 2 - 4 [51-102]
- 2 [51]
- 3 [76]
- 4 [102]
- 2 - 4 [51-102]
- 2 - 4 [51-102]

(Specify size/type) OUTLET

- _____ IC Inside Caulk
- _____ IG Inside Gasket
- _____ IP Threaded
- _____ IP Threaded
- _____ IP Threaded
- _____ NH No-Hub
- _____ NL Neo-Loc

'E' BODY HT. DIM.

- 3 7/8 [98]
- 3 7/8 [98]
- 2 3/8 [60]
- 2 5/8 [67]
- 2 7/8 [73]
- 3 7/8 [98]
- 3 3/4 [95]

PREFIXES

- _____ Z D.C.C.I. Body Assembly with Type 304 (CF8) Stainless Steel Top*
- _____ ZM D.C.C.I. Body Assembly with Type 316 (CF8M) Stainless Steel Top

SUFFIXES

- _____ -AR Acid Resisting Epoxy Coated Cast Iron
- _____ -G Galvanized Cast Iron
- _____ -P Trap Primer Connection (Specify 1/2 [13] or 3/4 [19])
- _____ -SF Satin Finish Top
- _____ -TC Neo-Loc Test Cap Gasket (2 [51] -4 [102] NL Outlet Only)
- _____ -VP Vandal-Proof Secured Top
- _____ -90 2 or 3 [51 or 76] Side Outlet Body Assembly

REV.	DATE: 03/19/13	C.N. NO. 128970
PROD./DWG. NO. Z415J-77		

*REGULARLY FURNISHED UNLESS OTHERWISE SPECIFIED