



Z100-201

SPECIFICATION SHEET

15 [381] DIAMETER ROOF DRAIN W/ PERFORATED EXTENSION, COVER AND AUXILIARY SIDE OUTLET

TAG _____

Dimensional Data (inches and [mm]) are Subject to Manufacturing Tolerances and Change Without Notice

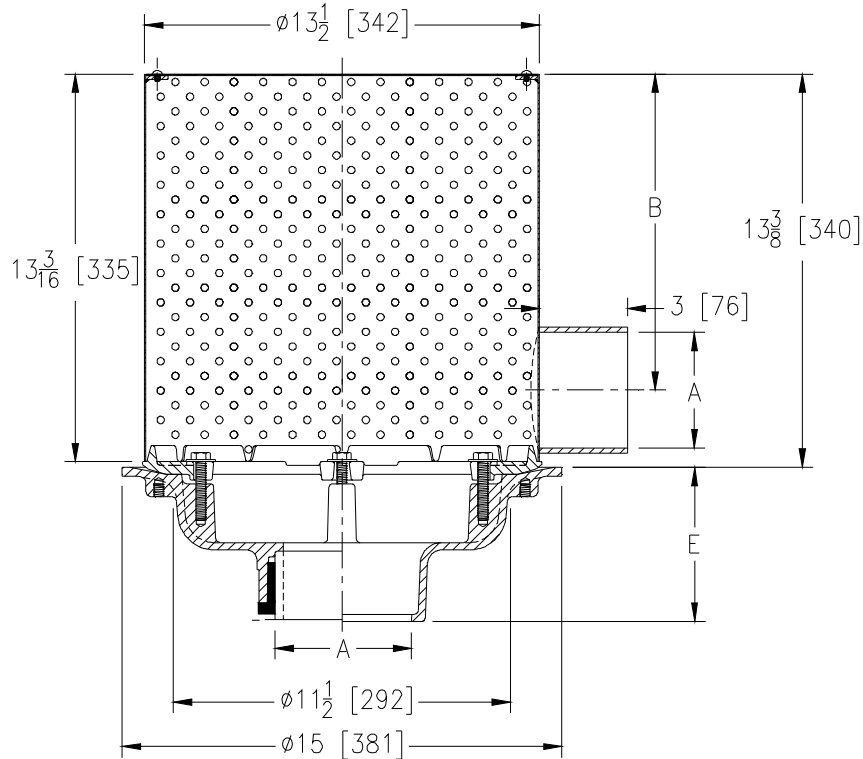

A Pipe Size In.	B	Approx. Wt. Lbs. [kg]	Cover Open Area Sq. In. [cm ²]
2,3,4 [51,76,102]	10 3/4 [273]	32 [15]	71 [458]
5,6 [127,152]	9 1/2 [241]	33 [15]	

ENGINEERING SPECIFICATION: ZURN Z100-201
15 [381] Diameter roof drain with combination gravel guard/ flashing clamp, perforated stainless steel extension and cover with auxiliary side outlet.

OPTIONS (Check/specify appropriate options)

PIPE SIZE

- 2 thru 6 [51 thru 152]
- 2 thru 6 [51 thru 152]
- 2 thru 6 [51 thru 152]
- 2,3,4 [51,76,102]

(Specify size/type) **OUTLET**

- _____ IC Inside Caulk
- _____ IP Threaded
- _____ NH No-Hub
- _____ NL Neo-Loc

E BODY HT. DIM.

- 5 1/4 [133]
- 3 3/4 [95]
- 5 1/4 [133]
- 4 9/16 [116]

PREFIXES

- _____ Z D.C.C.I. Body and Clamp Collar*

SUFFIXES

- _____ -AC Angular Underdeck Clamp
- _____ -AR Acid Resistant Epoxy Coated
- _____ -C Underdeck Clamp
- _____ -DE Deck Extension
- _____ -DP Top-Set® Deck Plate (Replaces both the -C and -R)
- _____ -DR Top-Set® Drain Riser
- _____ -E Static Extension 1 [25] thru 4 [102] (Specify Ht.)
- _____ -EA Adjustable Extension Assembly
- _____ -EB Top-Set® Adjustable Extension Assembly
- _____ -G Galvanized Cast Iron
- _____ -R Roof Sump Receiver
- _____ -TC Neo-Loc Test Cap Gasket
(2 - 4 [51 - 102] NL Bottom Outlet Only)
- _____ -VP Vandal-Proof Secured Top
- _____ -90 90° Threaded Side Outlet Body
(2 thru 6 [51 or 152])

*REGULARLY FURNISHED UNLESS OTHERWISE SPECIFIED

REV. DATE: 6/8/09 C.N. NO. 120061

DWG. NO. P-15718 PRODUCT NO. Z100-201

ZURN INDUSTRIES, LLC ♦ SPECIFICATION DRAINAGE OPERATION ♦ 1801 Pittsburgh Ave. ♦ Erie, PA 16514
Phone: 814/455-0921 ♦ Fax: 814/454-7929 ♦ World Wide Web: www.zurn.com

In Canada: ZURN INDUSTRIES LIMITED ♦ 3544 Nashua Drive ♦ Mississauga, Ontario L4V1L2 ♦ Phone: 905/405-8272 Fax: 905/405-1292