

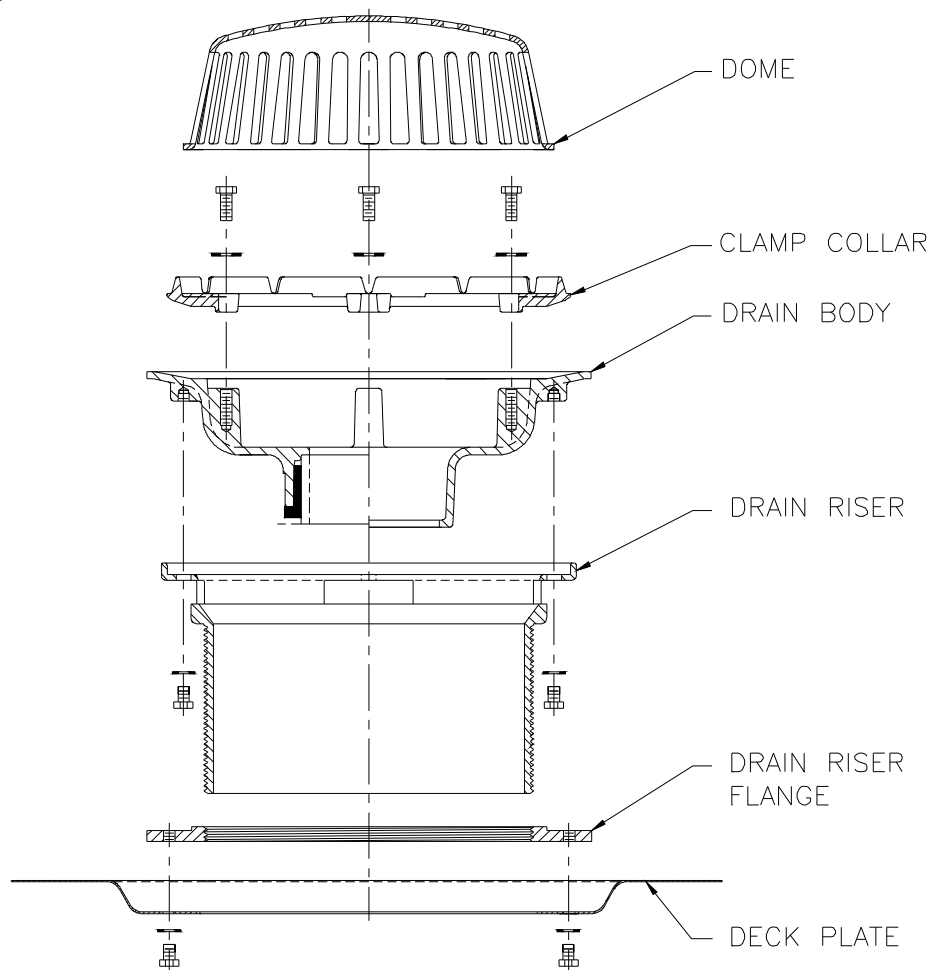

# TOP-SET<sup>®</sup> DRAIN RISER INSTALLATION INSTRUCTIONS

1. Create a square 18" X 18" opening in roof (Q-deck) to receive drain assembly.
2. Fasten drain riser flange to deck plate by aligning the (4) threaded holes on the flange and (4) slots on the deck plate using 3/8-16 X 1/2 bolts and (4) 3/8 flat washers provided.
3. Thread bolts from underside of deck plate, thereby fastening the deck plate between the bolt head and flange. Flange slots may be used as an alternative with other desired hardware. (not included)
4. Fasten the drain body to the drain riser sleeve by aligning the (4) threaded holes on the body and the (4) holes on the drain riser using 3/8-16 X 3/4 bolts and (4) 3/8 flat washers provided.
5. Put deck plate/flange assembly onto the precut opening in the roof, aligning deck plate attachment slots in the appropriate position.
6. Fasten the assembly to the roof with self-tapping screws. (provided by others)
7. Screw on drain body/drain riser sleeve assembly to deck plate/flange assembly on roof. Adjust to desired height.
8. Install insulation (if required) and secure waterproofing membrane to roof drain body with the clamp collar.
9. Attach dome to clamp collar to complete assembly.





# TOP-SET<sup>®</sup> DRAIN EXTENSION INSTALLATION INSTRUCTIONS

1. Create a square 18" X 18" opening in roof (Q-deck) to receive drain assembly.
2. Fasten drain extension flange to deck plate by aligning the (4) threaded holes on the flange and (4) slots on the deck plate using 3/8-16 X 1/2 bolts and (4) 3/8 flat washers provided.
3. Thread bolts from underside of deck plate, thereby fastening the deck plate between the bolt head and flange.
4. Fasten the drain body to the drain extension by aligning the (4) threaded holes on the body and the (4) holes on the drain extension using 3/8-16 X 3/4 bolts and (4) 3/8 flat washers provided.
5. Put deck plate/flange assembly onto the precut opening in the roof, aligning deck plate attachment slots in the appropriate position.
6. Fasten the assembly to the roof with self-tapping screws. (provided by others)
7. Set drain body/drain extension assembly onto deck plate/flange assembly on roof. Adjust step locations for desired height.
8. Fasten (3) set screws into flange side holes.
9. Install insulation (if required) and secure waterproofing membrane to roof drain body with the clamp collar.
10. Attach dome to clamp collar to complete assembly.

