



Z1761-79

5 [128] X 48 [2134] DRAIN W/ 7 [203] SUMP DEPTH, SIDE OUTLET, AND HEEL-PROOF BAR GRATE

SPECIFICATION SHEET

TAG _____

Dimensional Data (inches and [mm]) are Subject to Manufacturing Tolerances and Change Without Notice

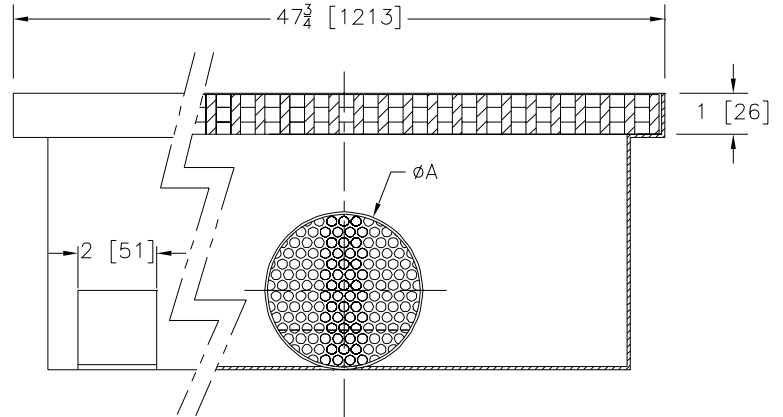
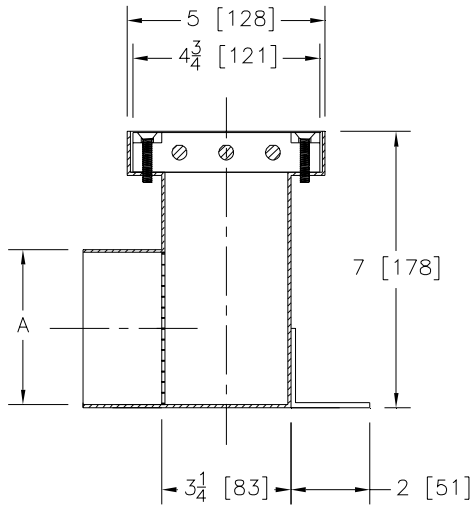

A Pipe Size In.	Approx. Wt. Lbs. [kg]	Grate Open Area Sq. In. [cm ²]
4 [102]	140 [64]	180 [1161]

ENGINEERING SPECIFICATION: ZURN Z1761-77
5 [128] x 48 [2134] x 7 [203] deep, 14 gage, Type 304 Stainless Steel drain with four anchor feet, sediment baffle and screen, with medium duty vandal proof lockdown (4 per grate) Heel-Proof bar grates.

OPTIONS (Check/specify appropriate options)

PIPE SIZE

4 [102]

(Specify size) **OUTLET**

____ NH No-Hub

PREFIXES

____ Z Type 304 (CF8) Stainless Steel Body and Grate

REV.	DATE: 7/5/07	C.N. NO. 96604
DWG. NO. P-15417		PRODUCT NO. Z1761-79

*REGULARLY FURNISHED UNLESS OTHERWISE SPECIFIED