



Z100-249

SPECIFICATION SHEET

Ø15 [381] MAIN ROOF DRAIN W/ ADJUSTABLE EXTENSION & 2-1/2 [64] HIGH STAINLESS STEEL PERFORATED DOME TAG _____

Dimensional Data (inches and [mm]) are Subject to Manufacturing Tolerances and Change Without Notice

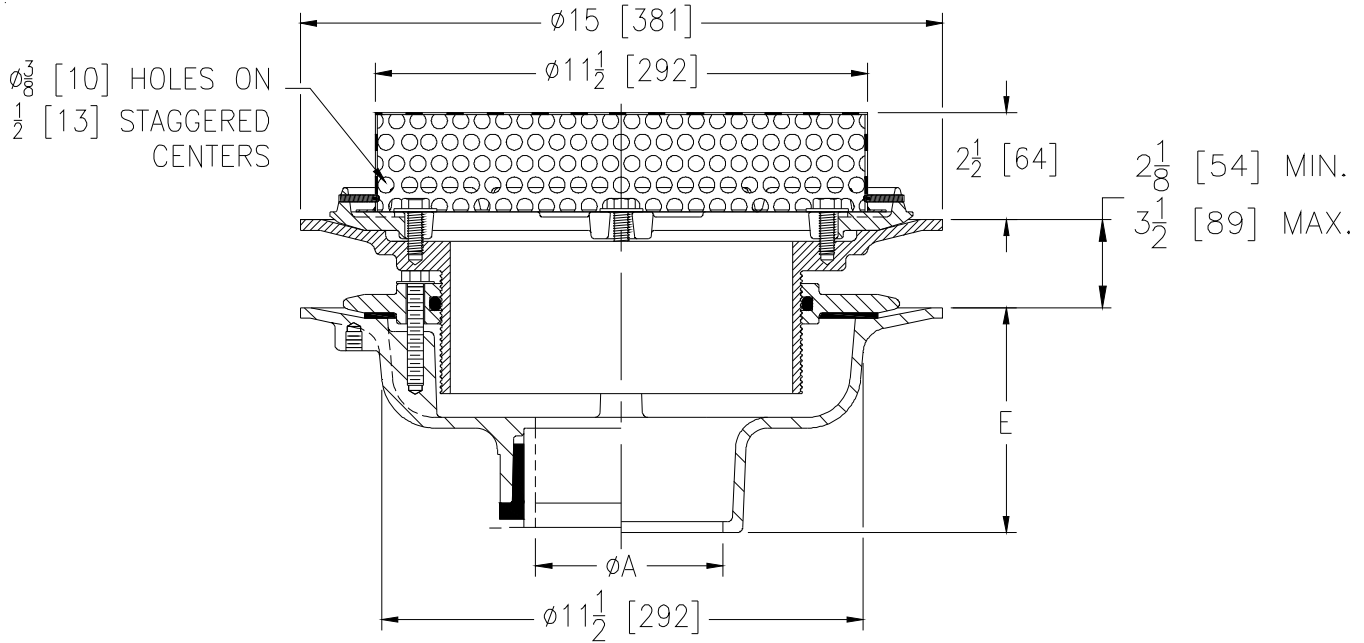

A Pipe Size In.	Approx. Wt. Lbs. [kg]	Dome Open Area Sq. In. [cm ²]
2,3,4 [51,76,102]	28 [13]	95 [613]
5,6 [127,152]	26 [12]	
8 [203]	29 [13]	

ENGINEERING SPECIFICATION: ZURNZ100-249

Ø15 [381] roof drain. Dura-Coated cast iron body with combination membrane flashing clamp/gravel guard, adjustable extension and 2-1/2 [64] high stainless steel perforated dome with Ø3/8 [10] holes.

OPTIONS (Check/specify appropriate options)

PIPE SIZE

- 2 thru 6,8 [51 thru 152,203]
- 2 thru 6,8 [51 thru 152,203]
- 2 thru 6,8 [51 thru 152,203]
- 2,3,4 [51,76,102]
- 6 [152]

(Specify size/type) OUTLET

- _____ IC Inside Caulk
- _____ IP Threaded
- _____ NH No-Hub
- _____ NL Neo-Loc
- _____ NL Neo-Loc

E BODY HT. DIM.

- 5-1/4 [133]
- 3-3/4 [95]
- 5-1/4 [133]
- 4-9/16 [116]
- 5-7/16 [112]

PREFIXES

- _____ ZS D.C.C.I. Body with Stainless Steel Perforated Dome*

SUFFIXES

- | | |
|---|---|
| _____ -AC Angular Underdeck Clamp | _____ -SS Stainless Steel Mesh Screen Over Dome |
| _____ -AR Acid Resistant Epoxy Coated | _____ -TC Neo-Loc Test Cap Gasket |
| _____ -C Underdeck Clamp | (2 - 4 [51 - 102] NL Bottom Outlet Only) |
| _____ -DE Deck Extension | _____ -84 Stainless Steel Perforated Gravel Guard |
| _____ -DP Top-Set® Deck Plate (Replaces both the -C and -R) | _____ -85 Stainless Steel Perforated Extension |
| _____ -DR Top-Set® Drain Riser | _____ -90 90° Threaded Side Outlet Body |
| _____ -DX Dex-o-tex Flange | (2 thru 6 [51 or 152]) |
| _____ -E Static Extension 1 [25] thru 4 [102] (Specify Ht.) | |
| _____ -EB Top-Set® Adjustable Extension Assembly | |
| _____ -G Galvanized Cast Iron | |
| _____ -R Roof Sump Receiver | |
| _____ -SC Secondary Clamp Collar | |

REV.	DATE: 06/27/12	C.N. NO. 124501
DWG. NO. 310009	PRODUCT NO. Z100-249	

*REGULARLY FURNISHED UNLESS OTHERWISE SPECIFIED

ZURN INDUSTRIES, LLC ♦ SPECIFICATION DRAINAGE OPERATION ♦ 1801 Pittsburgh Ave. ♦ Erie, PA 16514

Phone: 814/455-0921 ♦ Fax: 814/454-7929 ♦ World Wide Web: www.zurn.com

In Canada: ZURN INDUSTRIES LIMITED ♦ 3544 Nashua Drive ♦ Mississauga, Ontario L4V1L2 ♦ Phone: 905/405-8272 Fax: 905/405-1292