



# Z550-Y-90

## 9 [229] DIAMETER MEDIUM-DUTY DRAIN W/ SEDIMENT BUCKET & SIDE OUTLET

SPECIFICATION SHEET

TAG \_\_\_\_\_

Dimensional Data (inches and [ mm ]) are Subject to Manufacturing Tolerances and Change Without Notice

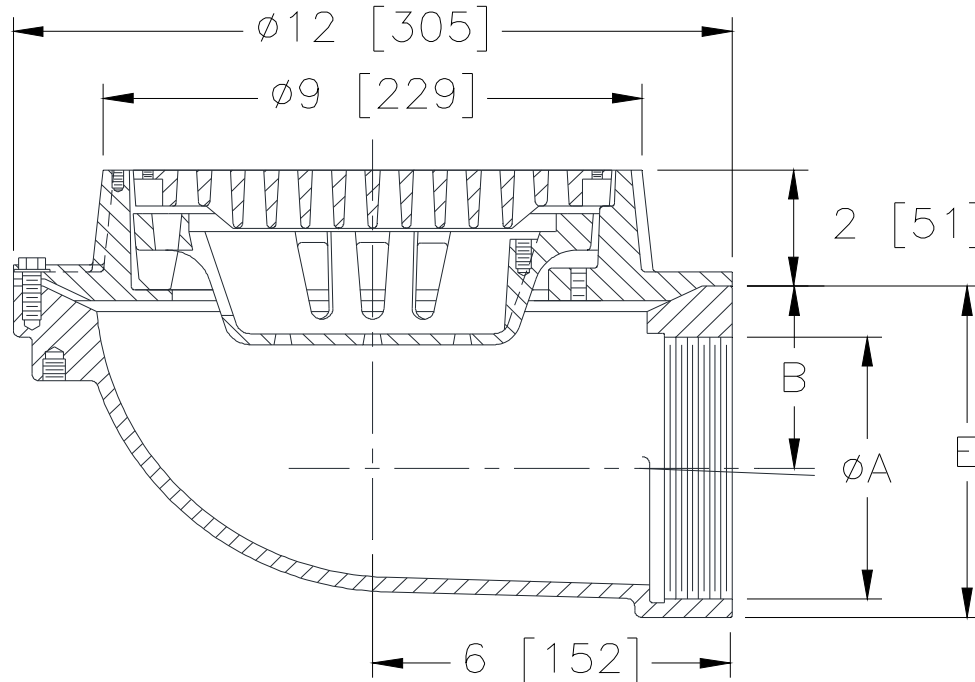

A- Pipe Size In. [mm]	B Dim. In. [mm]	Approx. Wt. Lbs. [kg]	Grate Open Area Sq. In. [cm <sup>2</sup> ]
3 [76]	3-5/8 [92]	43 [19]	18 [116]
4 [102]	3-1/8 [79]	41 [18]	

**ENGINEERING SPECIFICATION:** ZURN Z550-Y-90  
9" [229mm] Diameter top drain, Dura-Coated cast iron body with side outlet, seepage pan and medium duty cast iron heel-proof slotted grate and combination membrane flashing clamp and frame with sediment bucket.

### OPTIONS (Check/specify appropriate options)

#### PIPE SIZE

3,4 [76,102]

(Specify size/type) **OUTLET**

\_\_\_ IP Threaded

**'E' BODY HT. DIM.**

5-11/16 [144]

#### PREFIXES

- \_\_\_ Z D.C.C.I. Body and Grate\*
- \_\_\_ ZB D.C.C.I. Body w/ Polished Bronze Grate (Add 3/16 [5] to 2 [51] Dim.)
- \_\_\_ ZN D.C.C.I. Body w/ Polished Nickel Bronze Grate (Add 3/16 [5] to 2 [51] Dim.)

#### SUFFIXES

- \_\_\_ -AR Acid Resistant Epoxy Coated
- \_\_\_ -D Dome Grate
- \_\_\_ -DG Duresist Grate
- \_\_\_ -G Galvanized Cast Iron
- \_\_\_ -P Trap Primer Connection
- \_\_\_ -SS Stainless Mesh Liner for Bucket
- \_\_\_ -TS Top Secured with Slotted Screws
- \_\_\_ -VP Vandal Proof Secured Top

\* Regularly furnished unless otherwise specified.