



Z100-179

15 [381] DIAMETER MAIN ROOF DRAIN HIGH ALUMINUM
 DOME W/ UNDERDECK CLAMP, ROOF SUMP RECEIVER,
 PERFORATED EXTENSION AND SEDIMENT BUCKET

SPECIFICATION SHEET

TAG _____

Dimensional Data (inches and [mm]) are Subject to Manufacturing Tolerances and Change Without Notice

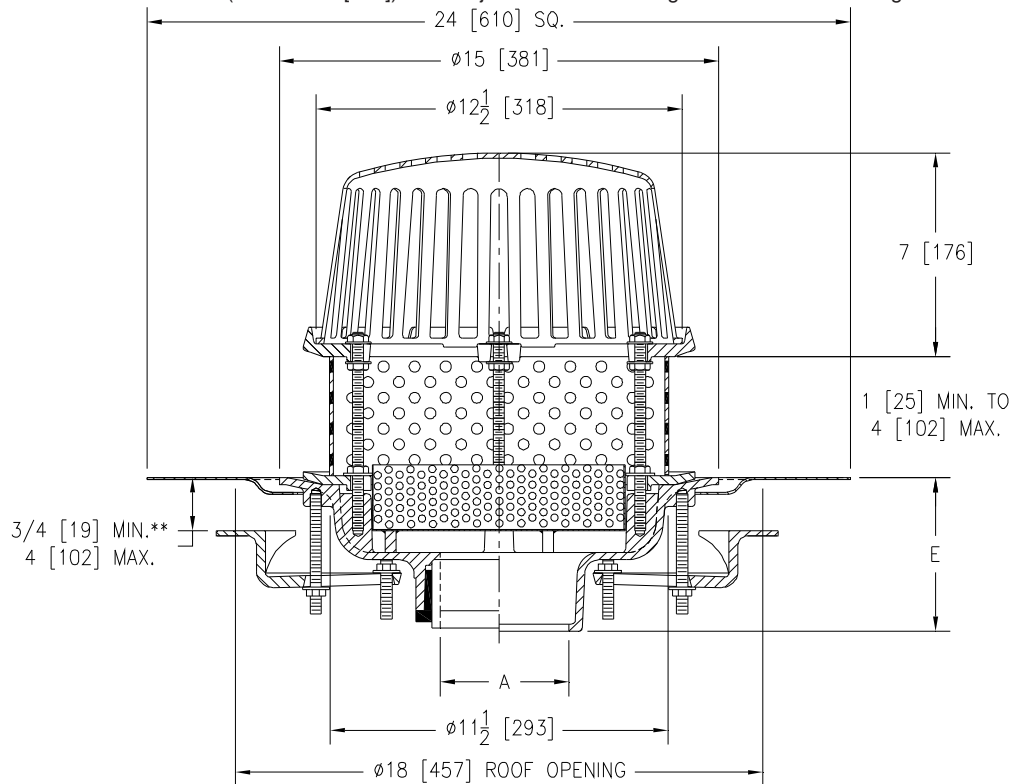

A Pipe Size In.	Approx. Wt. Lbs. [kg]	Dome Open Area Sq. In. [cm ²]
2,3,4 [51,76,102]	26 [12]	148 [955]
5,6 [127,152]	27 [12]	
8 [203]	28 [13]	

ENGINEERING SPECIFICATION: ZURN Z100-179

15 [381] Diameter roof drain. Dura-Coated cast iron body with combination membrane flashing clamp/gravel guard, 6 3/4 [171] high aluminum dome, roof sump receiver, perforated extension and sediment bucket.

PIPE SIZE

2 thru 6,8 [51 thru 152,203]
 2 thru 6,8 [51 thru 152,203]
 2 thru 6,8 [51 thru 152,203]
 2,3,4 [51,76,102]
 6 [152]

(Specify size/type) OUTLET

_____ IC Inside Caulk
 _____ IP Threaded
 _____ NH No-Hub
 _____ NL Neo-Loc
 _____ NL Neo-Loc

E BODY HT. DIM.

5 1/4 [133]
 3 3/4 [95]
 5 1/4 [133]
 4 9/16 [116]
 5 7/16 [112]

PREFIXES

_____ ZA D.C.C.I. Body with 6 3/4 [171] High Aluminum Dome *

SUFFIXES

_____ -AR Acid Resistant Epoxy Coated	_____ -TC Neo-Loc Test Cap Gasket
_____ -BS Bronze Mesh Screen Over Dome	(2 - 4 [51 - 102] NL Bottom Outlet Only)
_____ -DE Deck Extension	_____ -VP Vandal-Proof Secured Top
_____ -E Static Extension 1 [25] thru 4 [102] (Specify Ht.)	_____ -W2 2 [51] Internal Water Dam
_____ -EA Adjustable Extension Assembly	_____ -W3 3 [76] Internal Water Dam
2 1/8 [54] thru 3 1/2 [89]	_____ -W4 4 [102] Internal Water Dam
_____ -FG Flush Grate (Replaces Dome Strainer)	_____ -84 Stainless Steel Perforated Gravel Guard
_____ -G Galvanized Cast Iron	_____ -89 2 [51] High External Water Dam
_____ -GD Galvanized Cast Iron Dome (ZC Only)	_____ -90 90° Threaded Side Outlet Body
_____ -HD 6 3/4 [171] High Aluminum Dome Strainer	(2 thru 6 [51 or 152])
(148 Sq. In. [955 cm ²] Open Area)	
_____ -SS Stainless Steel Mesh Screen Over Dome	

*REGULARLY FURNISHED UNLESS OTHERWISE SPECIFIED

REV. DATE: 1/11/08 C.N. NO. 97964

DWG. NO. P-15508 PRODUCT NO. Z100-179

ZURN INDUSTRIES, LLC ♦ SPECIFICATION DRAINAGE OPERATION ♦ 1801 Pittsburgh Ave. ♦ Erie, PA 16514

Phone: 814/455-0921 ♦ Fax: 814/454-7929 ♦ World Wide Web: www.zurn.com

In Canada: ZURN INDUSTRIES LIMITED ♦ 3544 Nashua Drive ♦ Mississauga, Ontario L4V1L2 ♦ Phone: 905/405-8272 Fax: 905/405-1292