



Z1088-12 BACKWATER VALVE GATE TYPE WITH EXTENSION

SPECIFICATION SHEET

TAG _____

Dimensional Data (inches and [mm]) are Subject to Manufacturing Tolerances and Change Without Notice

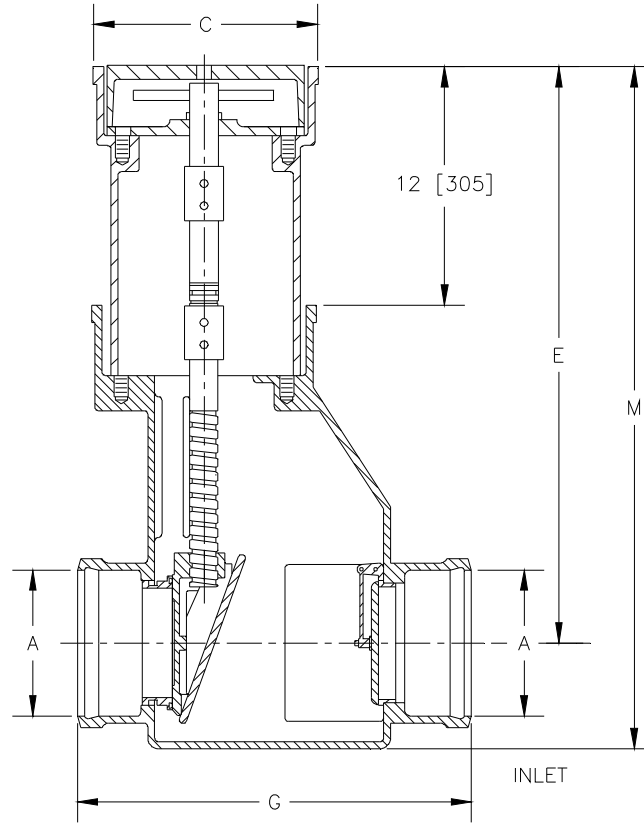

Dimensions In Inches				Approx. Wt. Lbs. [kg]
A Pipe Size	C	E	M	
4 [102]	8 [203]	24 [610]	27-3/4 [705]	100 [45.4]
6 [152]	10-1/2 [267]	26-1/2 [673]	31 [787]	140 [63.5]

ENGINEERING SPECIFICATION: ZURN Z1088-12 Gate Type Backwater Valve with extension, Dura-Coated cast iron body and extension with automatic PVC (4 [102] size only) flapper type backwater valve with O-ring adjacent to inlet and spade type bronze gate valve with O-ring seat insert adjacent to outlet easily controlled at floor level by covered handle engaging bronze non-rising stem.

CONNECTIONS (Check/specify appropriate options)

PIPE SIZE	(Specify size/type)	CONNECTION	G-LENGTH
4 [100]	_____	HB X HB Hub x Hub	14 [356]
6 [150]	_____	HB X HB Hub x Hub	16 [406]
4 [100]	_____	HB X NH Hub x No-Hub	18 [457]
6 [150]	_____	HB X NH Hub x No-Hub	20 [508]
4 [100]	_____	NH X NH No-Hub x No-Hub	18 [457]
6 [150]	_____	NH X NH No-Hub x No-Hub	16 [406]

PREFIXES

_____ Z D.C.C.I. Body and Cover with PVC Flapper Valve, Bronze Check Valve, Gate, and Stem*

SUFFIXES

_____ -BV Bronze Flapper Valve (4 [102] Size)
 _____ -G Galvanized Cast Iron
 _____ -WH Wheel Handle
 _____ -24 24 [610] Extension

*REGULARLY FURNISHED UNLESS OTHERWISE SPECIFIED

REV. C	DATE: 8/26/11	C.N. NO. 122003
DWG. NO. 58435	PRODUCT NO. Z1088-12	